



Cement and Building Materials Review

Published by:

Arab Union for Cement & Building Materials (AUCBM)

No. 91, March 2023



26th Arab International Cement Conference & Exhibition (AICCE26)

Riyadh, Saudi Arabia
November 2023

المؤتمر والمعرض العربي الدولي السادس والعشرون
لصناعة الإسمنت ومواد البناء
الرياض، المملكة العربية السعودية
نوفمبر/ تشرين الثاني 2023

Arab Union for Cement & Building Materials (AUCBM)

Event Secretariat:

aicce26@aucbm.email

www.aucbm.net

Contents



Arab News



International News



New Products



Diary dates



Articles

Keep the kiln rotating

By: Zeki Ozek, Ozek Makina Rotary Kiln Services, Turkey

Finding the value

By: Mark Mutter, JAMCEM Consulting, UK

Future trends in managing cement plants

By: Sanwar M. Mishra, India

Plug & play slip ring motor configuration for a cement mill - Carbon brush selection makes all the difference

By: Mathis Menzel, Menzel Elektromotoren, Germany

- The magazine editorial staff welcome the contribution of experts to enrich the contents of the magazine.
- Points of view expressed in the magazine do not necessarily express points of view of the AUCBM or the magazine itself. It is rather the opinion of the author.
- The AUCBM does not bear legal liability or responsibility from any article.

Editor-in-Chief

Eng. Ahmad Al-Rousan

Managing Editor

Suha M. Canaan

Graphic Designer

Yousef Ahmad

For advertisement
please contact Editor-in-Chief

Email

aucbm@scs-net.org
aucbm1977@gmail.com

Website

www.aucbm.net



AUCBM's *Quarterly Cement and Building Materials Review (CBMR)*

EDITORIAL SCHEDULE FOR 2023

ISSUE	THEMES	EVENTS
<p>June 2023 (# 92)</p>	<ul style="list-style-type: none"> - Bagging and packing - Loading/unloading and storage systems - Conveying solutions - Feeding technology - Belt bucket elevators - Materials handling in cement plants, quarries, terminals and ports - Domes, silos and transport - Wear protection - Gears, drives and lubrication - Fire protection systems - Maintenance procedures - Refractories - Quarry rehabilitation - Silo cleanout - Filters, dedusting 	
<p>September 2023 (# 93)</p>	<ul style="list-style-type: none"> - Coolers - Fans - Air cannons - Occupational health and safety - Comminution - Vertical roller mills - Increasing cement mill output - Crushing - Grinding & grinding aids - Waste heat recovery - Thermal imaging - Thermal recycling - Methods for treating and utilizing bypass dusts - Explosion protection in alternative fuel storage silos - Alternative fuels handling systems - Production and use of Solid Recovered -Fuels 	<p style="text-align: center;">AUCBM's 26th Arab International Cement Conference and Exhibition (AICCE26)</p> <p style="text-align: center;">Riyadh, Saudi Arabia November 2023</p>

December 2023 (# 94)	<ul style="list-style-type: none"> - White cement manufacturing - Blended cements - Multi-component cements - Slag cements - Green cement production - Cement blends / mixes - Cement additive - Cement composition - Cement chemistry - Zero carbon cement - Producing low-carbon clinker - Raw material for cement additive - Supply chain management - Energy-efficient cement production - Quality assurance and process control in cement plants - Cement Production cost saving 	
-------------------------	---	--

Deadlines for receiving articles, press releases, or advert materials for 2023 issues are as follows:

June issue: **30th May 2023**

September (bonus) issue: **31st August 2023**

December issue: **5th December 2023**

ADVERTISEMENT TARIFFS IN US DOLLARS

PLACE	Once insertion	Twice insertion	3-times insertion	4-times insertion
Outside Front Cover	1,250	****	****	****
Inside Front/Back Cover (Colored)	950	****	****	****
Full Page (Colored)	750	950	1,250	1,350
Half Page (Colored)	450	550	650	750
Quarter Page (Colored)	300	350	400	450
Full Page (B/W)	300	350	400	450

Size: A4

For the **outside front cover**, dimensions are: 20 (height) x 14 cm (width)

Resolution: 300dpi

File: PSD, EPS, or PDF

BANNERS (JPG) ON THE FIRST PAGE OF WWW.AUCBM.NET

US\$ 150 per month

Size is 200pixel w X 75pixel H

Resolution: 300dpi (please send with the requested link)

Algeria

GICA exports 3Mt of cement in 2022

The GICA group exported a total of 3Mt of cement in 2022. Destinations included countries in West Africa, Latin America and Europe. The group is working, through its various subsidiaries, to increase its cement exports as part of the government's strategy aimed at diversifying non-hydrocarbon exports.

As part of this, its SCIMAT subsidiary recently obtained ISO 45001 and ISO 50001 certificates relating to health and safety and energy management standards to help it increase exports to the EU and US.

Global Cement

GICA exports 350,000t of clinker in first two-and-a-half months of 2023

Groupe des Ciments d'Algérie (GICA) says that it exported 350,000t of clinker produced at its Chlef cement plant over the period between 1 January and 14 March 2023. The producer aims to export a total of 2Mt of clinker throughout 2023. It is currently on track to reach 1.75Mt, 13% short of its target, but 17% greater than its 1.5Mt exported in 2022. The company despatched the clinker from the ports of Oran and Tenès, to customers in Africa, Europe and South and Central America. It would now like to begin delivering its clinker to Syria and Türkiye in order to help facilitate rebuilding efforts there in the wake of the catastrophic February 2023 earthquake.

Global Cement

Lafarge Algeria signs agreement with National Centre for Cleaner Production Technologies

The National Centre for Cleaner Production Technologies (CNTPP) has signed a cooperation agreement with Lafarge Algeria. The arrangement is intended to provide government assistance towards producing cement more sustainably at the manufacturer's plants. The CNTPP is an organization setup by the Ministry of Environment to support industrial and commercial companies.

Global Cement

International Cementreview



Delivering business insight, market knowledge and technical expertise to the global cement industry.

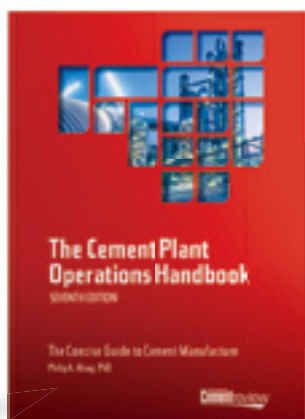

INCLUDES
FREE
HANDBOOK

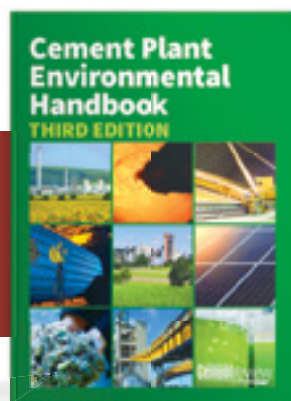

SUBSCRIPTIONS 2023

SUBSCRIPTION PACKAGE INCLUDES



MONTHLY MAGAZINE

12 issues of the cement industry's leading publication, delivered direct to your desk by First Class Airmail with early access to the digital magazine via CemNet.com.



FREE HANDBOOK

Choose between *The Cement Plant Operations Handbook, 7th Edition* and *The Cement Plant Environmental Handbook, 3rd Edition*.



ICR SUBSCRIBER DISCOUNTS

on all other reference works published by ICR.



BUILDING BULLETIN NEWSLETTER

Monthly newsletter covering the latest developments in the building materials sector – complimentary to all ICR subscribers.



FULL SUBSCRIBER ACCESS

to CemNet.com the industry leading website.



ICR SUBSCRIBER APP

via App Store or Google Play.

A COMBINED PRINT AND DIGITAL

ANNUAL SUBSCRIPTION TO ICR

GBP 220 / USD 315 / EUR 260



Subscribe online at
www.CemNet.com/subscribe

READ

ICR magazine
anywhere, anytime

SEARCH

the ICR archive of
digital back issues

ACCESS

premium articles

WATCH

video presentations
in high-definition

Egypt

El Nahda Cement Company agreement Renewal

Arab Swiss Engineering Company (ASEC) and Al Nahda Cement Company for Industry celebrate the renewal of the Operation & Maintenance (O&M) contract until the end of March 2026; a period lasting over three years.

The finalization of the renewal took place at Al Nahda premise in Qena last February.

This contract renewal shows Al Nahda Cement Company's continued confidence in the technical and managerial capabilities of ASEC, who has been managing the plant since 2011.

The two parties expressed their happiness with this agreement and the continuation of this fruitful cooperation in the upcoming period. Both look forward to a new phase of cooperation to achieve more success, progress, and prosperity for the two companies.

Abu Dhabi Ports Group secures Arish and Port Said cement terminals contract

The General Authority for the Economic Zone of the Suez Canal has awarded UAE-based Abu Dhabi Ports Group (ADPG) a contract to operate two cement terminals, at Arish and Port Said. ADPG plans to establish 60,000t-worth of additional cement storage capacity at the Arish cement terminal, and 30,000t-worth of new cement capacity at the Port Said cement terminal. This will give the two Mediterranean ports a combined cement despatch capacity of over 2Mt/yr. The company expects this to double Egypt's cement capacity upon the completion of both projects in late 2023.

Under the contract, ADPG has also gained a 30-year concession over the Safaga Port multi-purpose terminal on the Red Sea coast. It plans to invest US\$200m in an expansion to increase the terminal's dry bulk goods capacity to 5Mt/yr. It expects to commission the expanded facility in mid-2025.

Global Cement

University of Cairo team develops biocement using nanomaterials

Researchers at the University of Cairo have used nanomaterials from agricultural wastes to produce biocement with 'increased strength and durability' compared to ordinary Portland cement (OPC). The study employed microbially induced calcite precipitation (MICP) with the addition of carbon nitride nanosheets and ash from waste maize cobs. Besides its improved physical performance, the researchers also found that their biocement offers improved endurance against water permeability.

Global Cement

NAVIGATE TOWARDS SUCCESS

The cement industry knowledge your competitive advantage needs:

- **News:** daily newsletter delivered to 23,000 recipients, including CEOs, equipment manufacturers, consultants, and engineers in 160+ countries
- **Proprietary intelligence:** interviews with cement industry thought leaders and experts, including CEOs, executives, analysts and consultants
- **Market research:** high-quality research reports, including detailed market studies, competitive assessments, cement trade flows, and export opportunity assessments. Custom research available upon request
- **Data services:** statistical and data research tools offering industry practitioners a wealth of cement supply and demand data



Morocco

NovaCim cement plant in Morocco produces first cement

NovaCim's new 1.4Mt/yr cement plant at Ouled Ghanem near El Jadida has produced its first cement. Denmark-based FLSmidth supplied equipment for the unit including an OK type vertical roller mill, which it says is the first such installation of the product in the country. FLSmidth said in 2019 that it was going to build the plant for TEKCIM in conjunction with the Société Générale des Travaux du Maroc (SGTM). Full commissioning is scheduled for 2023.

Global Cement

Oman

UltraTech Cement acquires 70% stake in Oman-based Duqm Cement Project International

UltraTech Cement Middle East Investments Limited, a subsidiary of UltraTech Cements in UAE, has acquired 70% of Duqm Cement Project International, LLC in Oman.

Duqm Cement Project International LLC, an Oman-based company that operates in the mining (limestone) industry, was incorporated on December 20, 2017.

Global Cement

Saudi Arabia

Eastern Province Cement invites bids for Najibiyah clinker plant

Eastern Province Cement has invited contractors to bid for work on the construction of its planned 10,000t/day Najibiyah clinker plant in Basra Governorate.

The producer also plans to upgrade multiple decommissioned lines at its 3.5Mt/yr Al Khursaniyah cement plant.

Global Cement

Southern Province Cement to award Jazan cement plant line contract in early 2023

Southern Province Cement expects to sign a contract for construction of a planned 10,000t/day new line at its Jazan cement plant in early 2023. The company commenced tendering for technical and financial offers for the project in May 2022.

When commissioned, Southern Province Cement plans for the new line to replace the plant's older existing lines.

Global Cement

Yamama Cement expects clinker production to cross 30,000 tpd by 2025

Yamama Cement Company is expecting clinker production to exceed 30,000 tons per day following the launch of commercial operations at its new factory and relocation of the seventh production line to the new factory.

The expected completion date for the relocation project is in the second half of 2025.

The company has signed an agreement with China's Sinoma Overseas Development Company to relocate and install the seventh production line from the old factory to the new

factory, which has a production capacity of 10,000 tons of clinker per day, at an estimated cost of 830 million Saudi riyals.

The cement producer expects four percent growth in domestic cement demand to 48 million tons in 2023.

The anticipated growth will be equal to a three percent increase in demand for 2024-2026. The forecasted demand for the Kingdom is 49.4 million tons for 2024, 50.9 million tons for 2025 and 52.4 million tons for 2026.

Zawya

NEWSLETTER

**APPEARS FREE –
EVERY 3 WEEKS**



Always the latest insights
from industry and
development!



All events of the industry
with one click!

SIGN UP NOW!

www.zkg.de/newsletter

Carbon Re

A³&Co.[®] | TOGETHER FOR EXCELLENCE

New partnership to accelerate cement decarbonization

Carbon Re and A³&Co.[®] join forces to help manufacturers cut costs and CO₂ emissions

6 February, 2023 – Climate tech pioneer Carbon Re is joining forces with cement manufacturing consulting firm A³&Co.[®] to accelerate the decarbonization of the cement industry. The two organizations have signed a strategic partnership agreement and plan to work together to help cement manufacturers optimize production processes to reduce operational costs and carbon emissions to otherwise unachievable levels.

Carbon Re's Delta Zero industrial decarbonization platform can cut fuel use by up to 10% and CO₂ emissions by up to 20% and has been piloted in cement plants across 3 continents. For an average cement plant, emissions reduction can reach 50 kilotonnes of CO₂ emissions a year.

The platform uses artificial intelligence (AI) technology to model a cement plant's production environment and optimize processes for the lowest possible CO₂ output and fuel use, with no capital expenditure.

Sherif Elsayed-Ali, CEO and co-founder of Carbon Re, said: "Our technology is already having a huge impact on some of the world's

most energy-intensive industries. This strategic partnership with A³&Co.[®] will enable even more cement producers to benefit from the operational savings offered by AI as they tackle the challenge of cutting carbon emissions and rising fuel prices."

A³&Co.[®] has a team of cement industry experts offering advisory services ranging from Strategic Business Consulting and project management to their globally unique concept solution of Digital Maturity, with a key focus on sustainability. A³&Co.[®] aims to support the built environment with a focus on the cement industry as it tackles the challenge of reducing CO₂ emissions, with a calculated results-based solutions roadmap to ensure manufacturers remain competitive.

Amr Nader, CEO and co-founder of A³&Co.[®], said: "This strategic partnership with Carbon Re is one of our key international collaborations to drive decarbonization of the built environment with a focus on the cement industry. There is a lot of talk about the climate crisis but not enough action. This partnership is set to provide tangible benefits with measurable results for both cement manufacturers and the planet."

Heidelberg Materials acquires SER Group

Heidelberg Materials, Germany has recently acquired SER Group of Heilbronn, Germany. SER is focused on the demolition and construction materials recycling business. SER Group employs over 200 people and achieved an annual revenue of 50 Mio Euro. Heidelberg Materials expects to strengthen its position in the reuse of building materials and concrete recycling with this acquisition. The investment follows a similar intention like the acquisitions of RWG (Germany) and Mick George (England) late last year (we reported earlier). The acquisition is still subject to approval of the antitrust authorities, a transaction value has not been disclosed by either party.

[drymix.info News 279/2022](#)

Heidelberg Materials acquires recycling experts RWG (Germany) and Mick George (UK)

Heidelberg Materials, (HeidelbergCement AG) Germany, has recently acquired RWG Holding of Berlin, Germany (focused on demolition and construction materials recycling in Berlin area), as well as Mick George Group of Huntingdon, Cambridgeshire, United Kingdom (focused on recycling, quarrying, concrete and earth-moving). RWG Holding generated a turnover of around 50 mio Euro with its 250 employees in 2021, Mick George Group employs 1.000 people at more than 40 locations in the UK and reports an annual turnover of around 255 mio Euro. It can be assumed, that Heidelberg Materials aims at producing in-house alternatives to aggregates used in the production of concrete and thus lower its carbon footprint in this segment. The transactions are still subject to the usual anti-trust approvals, transaction values have not been disclosed by any of the parties.

[drymix.info News 282/2022](#)

Inocon-IP takes over Christof Industries

Inocon Industrial Plants GmbH of Attnang-Puchheim has announced the take-over of Christof Industries Austria GmbH of Wels (both Austria). Both companies are providers for the development, installation and servicing of industrial plants with a focus on drymix mortar plants (former Doubrava activities). Being active in the same business field, Inocon expects an increase of its turnover by 50% thanks to the integration of Christof Industries Austria. Inocon plans to also employ the full staff of Christof Industries (32 people). The transaction value was not disclosed.

[drymix.info News 280/2022](#)



M/s. Allan Smith Engineering Pvt. Ltd. is a name of repute in the Rotary Kiln Industry. We offer specialized maintenance services includes KILN Audit, grinding (Kiln Tire, Ball Mill Slide Ring, gear teeth, etc.), Assistance in Kiln and components, erections & commissioning, and kiln and component design review for upgradation. We are a professionally managed company to emerge as principal name in the field.

Our engineering services are designed and implemented at par with international standards and continuous upgradation in methodology with the knowledge centre based in Europe. Many times, we had received acclamation from overseas clients. Our ethical business practice and professional attitude have earned the trust of clients with reputed businesses.



ALLAN SMITH ENGINEERING PVT. LTD.

Reg. Off.: 612-B Wing, Lodha Supremus, Kolshet Road, Thane (West), Maharashtra 400607, India.

Landline Number: +91 22 4962 2220/1

Mobile Number: +91 98675 89351 / + 91 90046 76484 (+91 900 IN SMITH)

Email: admin@smithengg.in, ase@eurokiln.com | Web.: www.smithengg.in

OUR SERVICES:

- Kiln Audit
- Hot Kiln Alignment
- Repair & Maintenance
- Kiln Tyre & Roller Grinding
- Thrust Roller & Thrust Face Grinding
- Kiln Erection
- Kiln Diagnostic Maintenance
- Kiln & Component Design
- Analysis of Residual life
- Support Roller design review

SUPPLY:

- Kiln Shell
- Duplex Graphite Seal (Inlet & Outlet)
- Girth Gear Spring Plate
- Tyre & Support Rollers
- Chairpad Lubrication Bar
- Isostatic Graphite Block
- Design & Supply of Full floating Chair pad



WEMO Technique now part of the ALERS Group

WEMO-Techniek, Heemhorst International and ALERS BV will officially form the ALERS-Group as of 1 June 2022.

With the ALERS-group we have adapted our corporate identity for clarity and appearance towards our customers and suppliers. Watch the video for the presentation of our new corporate identity.

Quality control and testing: since WEMO-techniek was established, we have been engineering a range of solutions for taking, collecting, packing and testing samples. Over the years, we have built up a complete range of products with wide-ranging applications across a number of markets. Using these various products in modular solutions, there is always a solution to suit your needs.

Saint-Gobain (Chryso) acquires Matchem (Brasil) and makes offer for IDP Chemicals (Egypt)

Saint-Gobain, Paris, through its Chryso division, has completed the acquisition of Matchem, São Paulo, Brasil. Matchem is mainly active in the concrete admixtures business with plasticizers, air entraining agents, accelerators and for curing/setting control. Apart from São Paulo, the company operates a subsidiary in Pernambuco (North Eastern Brasil). Matchem, founded in 2011, has 50 employees and generated a turnover of 20 mio Euro in 2021.

Saint-Gobain/Chryso is also in final discussions of taking over its long-time partner IDP Chemicals, Giza, Egypt, with which a cooperation (licensing) exists since 2018. IDP produces also construction chemicals and employs 25 people. Saint Gobain expects to finalize the ICP acquisition in the first quarter of 2023. Transaction values were not disclosed for either deal.

BMR: a major new addition to the SACMI Group

Effective as of 27 February, this operation completes the plan laid out in 2019 when SACMI obtained a 20% stake in the Scandiano-based company: a big step forwards for SACMI's strategy of enhancing and extending its range of solutions for the Tiles sector.

As of 27 February 2023, BMR SpA is a fully-fledged SACMI company. This operation completes what was begun in 2019 when SACMI acquired a 20% share in the company (based in Scandiano, Reggio Emilia).

Already envisaged when SACMI entered BMR as a minority shareholder, the option of purchasing/selling residual shares was implemented as per the planned timeline. As the President of SACMI, Paolo Mongardi, explains, this reflects how "BMR fully shares the same business and industrial development goals".

Founded in 1968, BMR is the industry's leading supplier of Made in Italy technologies for squaring, cutting, lapping and ceramic surface treatment. In 2022, company revenues touched € 96 million.

As a SACMI partner - and, as of today, a bona fide Group company - BMR has enhanced the business/technological reach of the Tiles sector: it complements the SACMI plant engineering approach and offers solutions that meet the growing need to integrate every processing stage downstream from forming and firing.

BMR has 138 employees. Within the existing partnership framework, they've brought SACMI a wealth of technical skills, a solid reputation and valuable customers. Now, in this new set-up, those skills will prove to be more valuable than ever, marking BMR's definitive entry into the SACMI family.



RAK buys SACMI robotglaze for its headquarters in UAE

The latest design glazing line follows on from the first supply, which has already been in production for years with great success. The goal: total automation both for glazing and handling with all the advantages this offers in terms of product logistics and development.

The multi-national sanitaryware company producing 5 million pieces per year, with 21 plants and customers in 150 countries, RAK Ceramics finalizes a project with SACMI to modernize and optimize its plant at Ras Al-Khaimah, in the United Arab Emirates, at the Group headquarters.

The project regards “Sanitaryware I” where, as part of the expansion plan explained above, RAK has chosen to install a new SACMI robotized cell to glaze different pieces especially the modern one-piece WCs.

With this supply RAK invests in the latest-generation Gaiotto solution. Not just the 8-axis robot, served by 4-position carousel, but also a complete solution including automatic handling from loading to unloading with two bar-conveyors connected by angle transfer device.

The GA2000 model robot is equipped with self-learning software to assist the development of new products/glazing programs. The system is equipped with Mass Control® to regulate the flow-rates of the glaze, allowing personalized settings to be made directly from the joystick according to the different models.

Finalized in October 2021, the supply contract is part of a wider plan for the constant and continuous application of the most modern technology, confirming a global partnership between SACMI and the RAK Group both as regards Sanitaryware lines and Tiles supplies. In addition to the upgrade and expansion of the production unit, the project aims to optimize production capacity and logistics at the site in Ras Al Kaiman, including much work to extend and optimize existing systems.

Porcelanosa starts up new large-size slab factory

Porcelanosa Group’s Plant 4 came into operation at the beginning of the year and will produce 1.3 million sqm/year of sintered stone slabs to be sold under the XTONE brand name.

Spanish ceramic tile manufacturer Porcelanosa Group recently started up a new 36,000 square metre facility at its headquarters in Vila-real for a €55 million investment.

Plant 4 began operation earlier this year and will use state-of-the-art automation and technology to produce large-format porcelain and sintered stone surfaces under the Xtone brand name. The new facility has created 125 jobs and will have an annual output of 1.3 million square metres of 320x160 cm and 270x120 cm size slabs with thicknesses of 6, 12 and 20 mm. However, the installed production systems are capable of producing slabs in thicknesses of up to 30 mm and sizes of up to 360x160 cm, a special format that caters for the needs of the architecture segment.

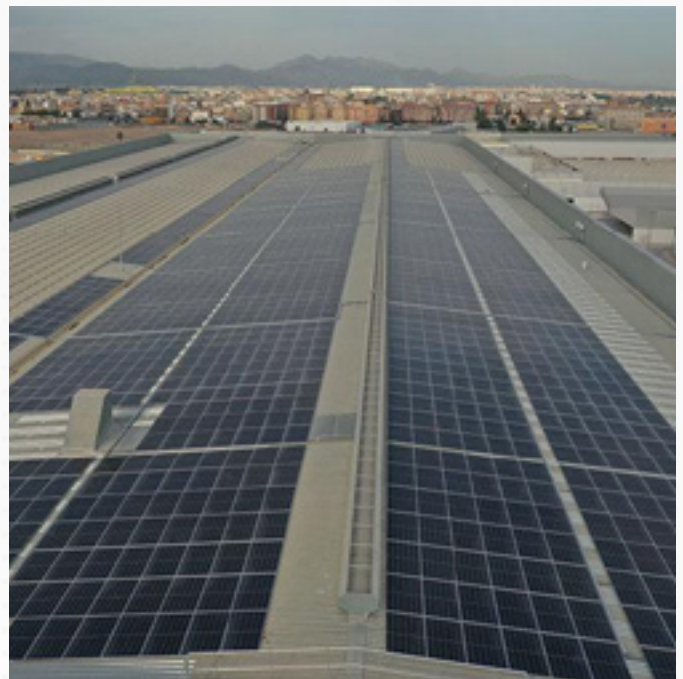

As a latest-generation smart factory, the plant stands out for the extremely high level of automation it achieves in all stages of the production process. Raw materials reception is automated using control software, while the pressing department uses the two most advanced presses on the market integrated with the latest 3D design technology. Glazing, decoration and texture creation are performed by a single system that achieves higher quality and resolution.



The firing department is equipped with a 250-metre-long kiln that produces products with the highest levels of technical performance ready for the subsequent cutting and finishing stages. A digitalised inspection system serves to sort and classify individual slabs and ensure that each piece comes up to the required quality standards.

For finishing operations, the post-production department has been equipped with a polishing line and a 100% automatic dry grinding line.



A highly sustainable factory

To increase energy self-consumption at the new plant, a total of 4475 solar panels with an output of 2.4 MWp have been installed on a 12,000 square metre photovoltaic roof, one third of the entire surface area of the new facility.

To minimise the environmental impact of the processes, the sustainability measures adopted at Plant 4 include recovery of 100% of the heat from the kiln for use in the dryer, reuse of 100% of the water via an industrial treatment plant and recycling of 100% of waste, which is fed back into the production cycle.

The international expansion of large-format XTONE slabs

The new production capacity available following the start-up of Plant 4 will enable Porcelanosa Group to significantly increase the sales of XTONE, the group company specialising in the sintered and natural stone slab segment. Last November, XTONE also announced the opening of twenty showrooms, referred to as Libraries, in Spain, Germany, the United States, Scotland, France, Italy and Brazil. The aim is to strengthen the company's national and international presence by creating its own extensive distribution network, to give a further boost to its business and to consolidate the brand as a benchmark in the large-size slab sector.

Visitors to the Library centres will find a selection of sintered stone products in sizes 150x300 cm (thickness 6 mm) for floors, walls, furniture and façades and 160x320 cm (thickness 12 mm) for kitchen countertops. Natural stone surfaces with thicknesses of 20 and 30 mm are also on display.

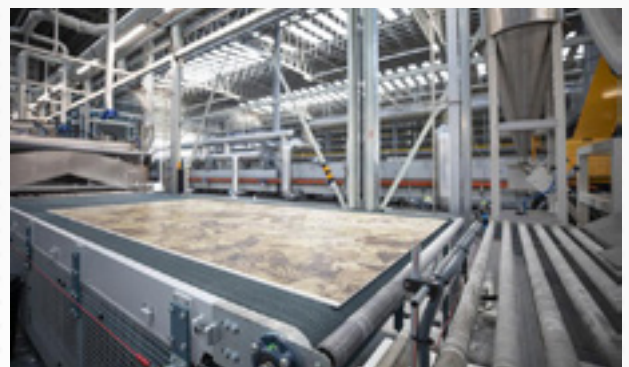

ЦЕМЕНТ

и его применение

CEMENT AND ITS APPLICATIONS
INDUSTRIAL JOURNAL

SINCE 1901

News

Markets analysis

Science, technology, production

Solid partners

Effective advertising



The journal for producers and consumers of cement and other binders, as well as for construction companies and equipment producers

The Russian-language periodical professional publication devoted to the production of cement and other binders, concretes, dry mixes and their applications, as well as to research and design.

A conspicuous place in the journal materials is given to the problems of plant development, capital movement, economic problems facing the cement industries of Russia and other countries.

The journal comes out once in two months and includes news, analytical materials and detailed abstracts of all the articles in English.

«Cement and its Applications» is the only initiator and organizer of international cement conferences PetroCem. PetroCem 2018 which was held on April, 2018 in Saint-Petersburg, Russia – gathered more than 520 participants from 36 countries and representing more than 320 companies.

Jcement.ru web-based information portal on cement. Production, technologies, science. Always up-to-date news and data on cement producers, technologies, equipment suppliers and key-players. Journal, interviews, statistics, events, Q&A and other relevant materials.

Cement and its Applications, Journal
22 A Zvenigorodskaja Str. No 438
St. Petersburg, 191119, Russia

Tel. +7 (812) 242-11-24

E-mail: info@jcement.ru

Web: www.jcement.ru

www.petrocem.ru



Keep the kiln rotating

Zeki Ozek, Ozek Makina Rotary Kiln Services, Turkey offers some insight into maintaining rotary kilns in a cement plant.



Cement production is a constant task that continues for decades with increasing quality and quantity goals. So keeping the equipment maintained to carry that load is the fundamental for that sustainability.

As we all know with our hard learned experience; a rotary kiln is a device to calcine and transfer thousands of tons of raw mix from feed inlet to outlet. The mechanics of a rotary kiln is actually quite simple. A large tube to carry the material, refractory to protect the tube shell from that enormous heat, tyres to hold the tube, chairpads to protect the tyre and shell from the thermal expansion issues, rollers to carry the whole weight, gears to rotate the system and slope to transfer the calcined material.

Keeping that simple mechanics under control when the size is that big and the temperature is that much necessitates a precise and experienced observation to understand the current condition. We may put these main tasks to our observation list as basics to keep the kiln rotating.

- Control the thermal expansion.
- Avoid excessive temperature and its deformation on the shell.
- Make sure all the piers are axially aligned and the load is distributed proportionally to the rollers.
- Check and control the axial migration of the kiln.
- Check the tyre and rollers' surface form.
- Check the drive system.

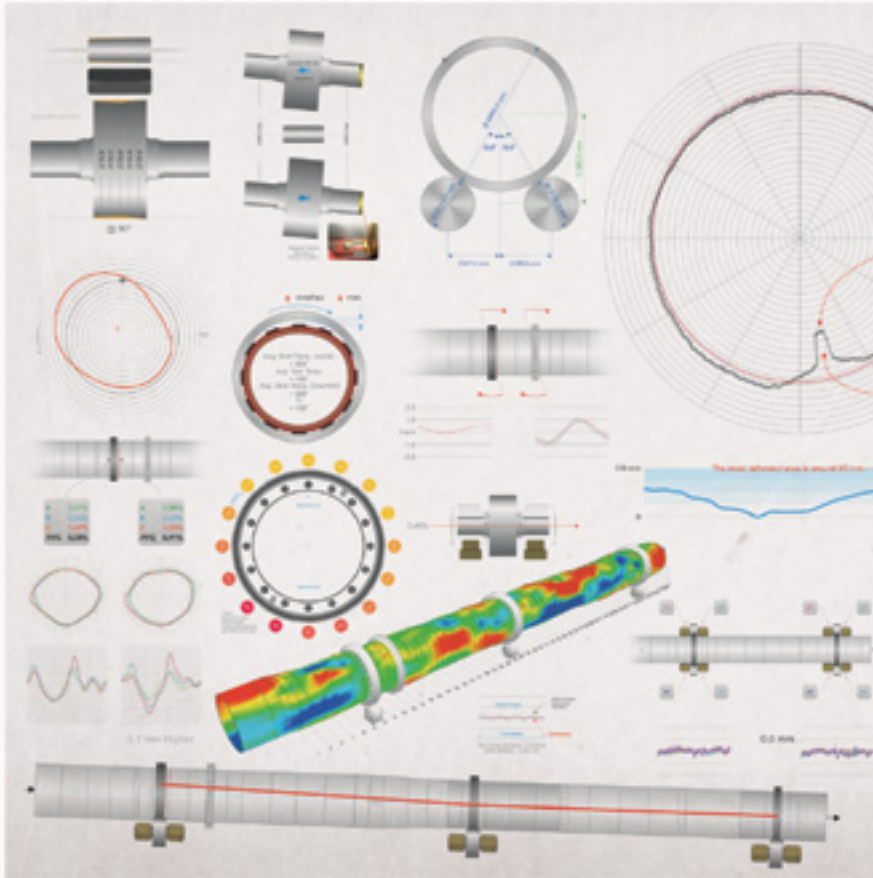

Figure 1: Visualization of the kiln inspection data.

Almost none of these headings are visible to the inexperienced plain eye and in most cases they are not predictable till they turn into a shut down issue. That's why you need a professional hot kiln alignment service annually or biannually to take a technically detailed photo of your kiln that provides you a guide for preventive maintenance.

Hot kiln alignment.

Hot kiln alignment is the generic name of those detailed inspections and measurements in hot and running condition. A lot of mechanical inspection types and methods might be added to that list but we will discuss the most important ones here.

Basically the whole weight of the material, refractory, shell, chairpads, tyres and girth gear is carried by the supporting rollers. So it is important to distribute the load to all these rollers proportionally depending on their designed position and current condition. Any capacity increase over the time will change the weight, the sintering zone and the thermal expansion as it happens in most of the kilns. The tyre and roller diameters change over time due to excessive wear, changed thermal expansion or replacement. Probably some minor or major roller skewing or repositioning actions also took place in maintenance history. So understanding the current situation precisely is a must before taking any preventive action.



Figure 2: Several measurement setups.

Axial deviation of ground fixed elements.

The kiln might be separated to three sections at this level. The ground fixed elements such as rollers, bearings, drive units. Rotating elements such as shell, tyres and girth gear. And the relation between these fixed and rotating elements under the excessive temperature circumstances.

Theoretically we have a virtual triangle between the geometric centers of the tyre and rollers at each pier. Measuring the tyre and roller diameters and distance between the roller centers precisely helps us to determine the exact projection of the tyre center over the roller center line. We may easily find out any axial deviation by combining each pier's triangle. Any diameter, height or slope difference between the rollers, any height difference between the tyres and any elevation difference between the piers should be carefully added to this calculation and interpreted carefully with remarkable experience. Actually here it is the most complicated chapter where half a millimeter may turn everything upside down.

The surface form of the tyres and rollers are also determined during the diameter measurement section so we know which rollers are conical and which ones are concave from now on. This is also visible at the contact surfaces of the tyres and rollers. We may judge the tyre/roller relation with the information of the roller skew, kiln slope, independent roller shaft slope and their accordance.

All these inspections lead us to check the actual position of the roller inside the bearing. This is simply visible under the housing inspection port. The gap between the bearing and the thrust disc and its side indicates the roller's position and its duty at the axial movement of the kiln.

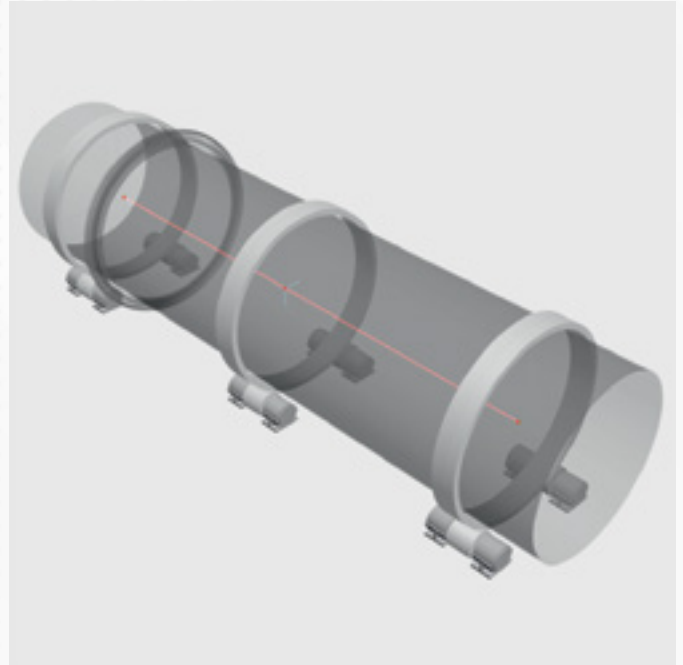

Figure 3: Axial deviation of the kiln piers.

At this point, we have information about the position and condition of the fixed elements. We may relocate the rollers to the required position and remove any axial deviation. We may solve any bearing temperature issue by skewing the roller and gaining bearing/thrust disc gap or solve the shaft/bearing relation issues. We may arrange the independent roller slope issue by simple shimming under the housing. Any axial deviation or mislocated support in other words may lead to excessive tyre and roller wear, surface and/or shaft cracks or even shell crack in long term if left that way.

But are we allowed by the rotating parts? Is there any change in their plastic form? Are they really rotating around their geometric center?

Thermal expansion of rotating parts.

The heat that is transferred to the shell may reach up to 450°C at around the sintering zone. The shell flexion may erode the refractory lining as a result of gravity that may end up with a brick fall down and cause local hot spots directly on the shell. The refractory may get thinner over time and therefore the shell temperature may increase or the material coating may reduce it locally.

At 400°C, the shell loses 50% of its tensile strength and, over that temperature, shell distortion is permanent. The overall issues at the heat distribution may end with a thermal crank of the entire shell or even further turn to a mechanical crank when combined with axial deviation and excessive stable temperature.

The goal is conserving the requested heat distribution over the entire shell which is used to predict the thermal expansion and calculate the required air gap between the tyre and chairpads. Actually that gap and the tyre creep caused by it is your main inspection spot along with the thermal scanner data to understand the ongoing thermal issues. The creep of the tyre is the easiest indicator to observe. Low creep value indicates less air-gap that leads to a tight tyre/shell relation. We may assume that the shell is over expanded due to excessive temperature and/or misuse of cooling fans.

For example over cooling the shell will increase the gap while over cooling the tyre instead will reduce it dramatically. Any mislocated cooling fan which can not separate where to cool will lead to unimprovable plastic deformations and even further to tyre cracks. The operator should be sure about proper cooling and cooler position. However, an excessive air gap gives room to the shell for more flexion (ovality) and therefore more motion and wear at the shell section welding and refractory. Uncontrolled

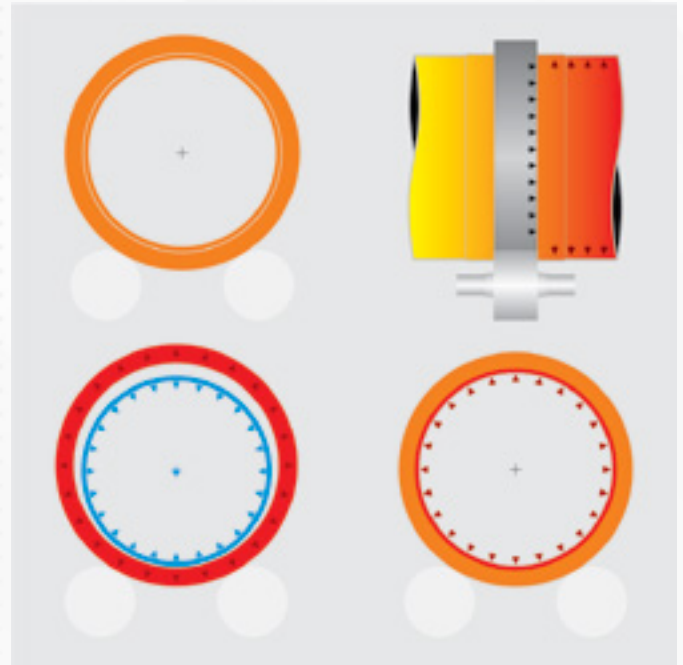

Figure 4: Thermal relation of the shell and tyre.

thermal expansion may change the tyre diameter dramatically and may lead to axial deviation and its mentioned damages easily in mid term.

The shell itself is a long large steel tube and it behaves just like a balloon full of water under uncontrolled thermal conditions. Most of the kilns are supported at every 20-25 m and the sections between these support piers are alone against the gravity. So the bending is an inevitable result of long term running and it may get worse by the help of shell corrosion, material coating, torsion caused by the gear, lost tensile strength and turn to a mechanical crank. The shell rotates just like a crankshaft in that case and keeping the fixed elements at proper position is not enough alone. The root clearance of girth and pinion gears may change dramatically in one whole rotation.

The load at the roller may change in a rotation and shift between the rollers of the same pier and that may even lead to a non-rotating roller in some cases. Keep in mind that a non-rotating roller also means a double loaded stablemate roller.

At Özek Makina, we laser scan the whole shell and get a real time 3D model of it to determine the plastic form, rotational behaviour and mechanical crank. That detailed scan gives us a quite useful 3D animation which we also provide to the client to calculate and judge the shell's effect on the dynamic load changes which rollers have to face. That data is also confirmed by several other inspections such as roller shaft bending. It should not be forgotten that shell/tyre relation is very important at this point that a tight mounted tyre behaves rigidly along with the shell and transfers all that dynamic load to the rollers; however a loose one will let the shell's crank motions be damped inside.

This much detailed scans and inspections will help a lot at preventive maintenance of minor issues. But when it comes to an over deformed, cranked or corroded shell it is just a clarification of the known with details of shell sections to be replaced and where to cut. An overdeformed shell may easily lead to roller shaft cracks, tyre/roller surface cracks and refractory issues which cause unexpected annoying kiln stoppage.

Tyre and roller relation.

Determining the position of the fixed elements and the form of the rotating elements is a tough but enlightening task that lets you understand the current kiln behaviour in numbers clearly. But a rotary kiln is located with a slope for easier material flow and more importantly it is not held by any fixed apparatus. If we keep all rollers unskewed (parallel to the kiln and tyres) the kiln will go all the way downhill. We have thrust rollers to stop it but these rollers should actually be used as the last punch. So we skew the rollers precisely to avoid excessive uphill or downhill force, keep the tyres in its place and arrange the axial migration of rotating parts. A hydraulic thrust roller is an important tool to understand and follow the necessary load to push uphill and arrange the roller skew from time to time.

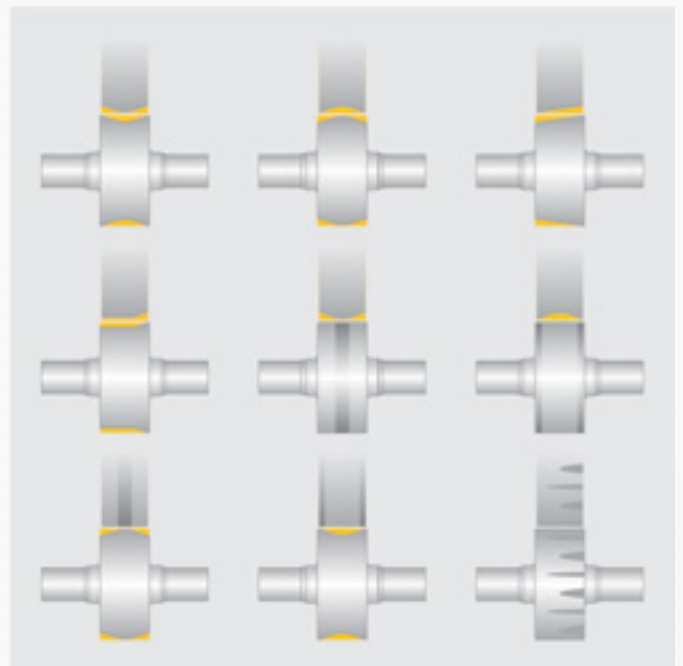

Figure 5: Types of tyre and roller wear form.

Roller skew / alignment.

The roller is designed with a shrink fit combined shaft. In most cases there is also a thrust disk but this is hidden under the hood, inside the housing. We may use the distance between this thrust disk and the bearing as a measure of the roller's effect on the axial migration of the kiln. Most housings have a cover to check the shaft and lubrication, which should be kept closed to protect the bearing and the shaft. Once you open this cover, you will notice that the thrust disk leans on the bearing and is not lubricated well or there is a gap between them. Depending on the design, that thrust disk might be on the outer or inner side of the shaft.

Let us say you see the tyre rotating uphill when you stand across the kiln facing the tyre. The maintenance team highlighted excessive temperature at the downhill bearing. You have opened the cover and noticed that there is no gap between the thrust disk (which is located on the inner side between the bearing and the roller) and the bearing. The thrust disk is forcing the bearing downwards during its downwards movement attempts, which damages the disk

and heats the bearing and the oil. That disk is actually helpful, as it would be worse if you had only noticed the situation once the roller was completely out of its housing.

When you face the tyre, if it is rotating up, the roller will also leave the pushed bearing behind. If the tyre is rotating down, the roller will also come to the pushed bearing. By pushing the downhill bearing in, the roller will move uphill and increase the gap between thrust disk and the bearing, solving the problem. (Keep in mind that if the thrust disk is located on the outer side, that attempt will reduce that gap and increase the temperature even higher.) A domino effect. The shell always moves in the opposite direction to the roller. In our case, the roller moved uphill when we pushed the downhill bearing in, so the kiln started to move downhill. Now you are at a point where you need the hot kiln inspection report. Some of the rollers were already at the limit of their bearing/thrust disk relation and were starting to increase the temperature. Perhaps the load on the thrust roller has been increased or reduced, or a conical or wavy roller started to move downhill with the kiln.

Figure 6: Roller skewing.



Tyre and roller surface machining and grinding.

Reduced tyre/roller contact is the corollary result of that compulsory roller skew. And that leads to more wear on the contact area. So the process to a conical tyre or roller starts. That wear increases the contact and necessitates additional skew and it goes on. At some point you decide to change your whole kiln alignment and the same wear starts on the other side of the roller. We may mention lots of variation on the scenario but in most cases the loop ends with very limited tyre/roller contact where all the load stress is carried by only a small portion with lots of surface cracks. Moreover any additional skew does not affect much since the contact is gathered mostly in the middle.



Figure 7: Insitu machined and grinded tyre and roller.



Figure 8: Insitu tyre machining at 3,5 rpm.

Once you resurface the tyre and the roller as a set, you increase the contact between tyre and roller, clean out the horizontal waves that cause vibration and the vertical waves that lock the roller to the tyre during the axial movement. It is completed once the pier is again aligned to balance the reduced diameter.

Now you are ready to arrange the roller skew and let the whole kiln migrate axially in desired limits.

Depending on the wear level, material, and the finish requests, grinding or machining with late bid might be chosen separately or together for resurfacing.

Sure, the speed of the kiln during resurfacing services should not affect your production but your production needs should also not affect the final surface quality.

Finding the value

Mark Mutter

Managing Director - JAMCEM Consulting

Introduction

Over the past 12 years, JAMCEM Consulting has successfully completed over 15 Due Diligence assignments. Whilst the majority of these assignments have been for various different Mergers and Acquisitions within the cement, aggregate and ready-mix concrete sectors, we have also worked for different parties considering funding the development of new technologies for cement manufacture - in particular for the reduction of CO₂ emissions - and alternative products to traditional Portland cement. Within this article we discuss key aspects any kind of Due Diligence and what can make the difference between a good and bad outcome in relation to the investment decision.

Why is a Due Diligence required?

Whilst this may appear to be a stupid question with an obvious answer, there are several examples of multinational cement producers who have completed acquisitions without completing a detailed due diligence, which have led to major long term financial issues and in one case their eventual demise when they were taken over by their biggest rival.

One of the definitions of the term Due Diligence is “a comprehensive appraisal of a business undertaken by a prospective buyer, especially to establish its assets and liabilities and evaluate its commercial potential”. In simpler terms, the process aims to ensure that you get what you pay for and that you pay the right price for the business or assets.

The Due Diligence team will normally be made of up various different parties such as:

- The Buy-Side team
- The Buy-Side deal advisor
- The Technical/Operational Advisor
- The Legal Advisor
- The Environmental Advisor
- The Financial Advisor
- The Commercial/Market Advisor

Whilst this team may appear to be very “heavy”, each has a critical role to cover in the assessment. What is clear, from our experience, is that the Technical/Operational Advisory role – which is normally undertaken by JAMCEM Consulting – has an input into almost all of the other Advisory roles that are part of the team. This occurs because the other Advisors are generally cross-sector professionals who do not have in-depth knowledge of the cement industry and therefore must rely on the knowledge of the cement industry consultant for guidance in their work.

The Due Diligence process itself generally works in two distinct phases – the desktop phase and the site visit phase (although in the case of the new technologies/products, the site visit phase is more often replaced with detailed discussions with the companies seeking investment). The desktop phase involves the thorough analysis of the information provided to the Buy-Side by the Sell-Side via an electronic dataroom. Quite often, the information will not be sufficient and therefore requests for further clarification or additional data from the Sell-side is required; therefore it is important for sufficient time to be left between the desktop phase and the site visit, in order to be able to have a full understanding of the historic performance of the plant and to identify the areas that require the most attention during the site visit itself.

The site visit should ideally last somewhere between ½ and 1 day per plant, depending on whether the site is a grinding plant or a full integrated plant. Certainly, for an integrated plant, we would expect a significant period of this time to be devoted to the quarries and deposits of the plant i.e. the limestone quarry and the clay/shale reserves. Subsequent to this we would inspect the plant from crusher through to packing plant, checking the overall condition of the plant and using the time with the plant personnel to provide answers to the questions that have arisen from the information from the dataroom.

The site visit also gives an excellent opportunity to assess the way in which the plant is being operated – for example the level of general housekeeping (and it is normally quite obvious to tell if the plant has been cleaned for the visit or whether it is generally looked after), the number of personnel around the site, the contents of the stores and workshops etc. Visits to the control room can be an extremely useful source of information, both through talking to operators as well as viewing key operating parameters on the CCR screens – validating the performance of the plant compared to the claimed performance in the dataroom.

It is always highly advisable to agree the duration and locations that will be visited in advance with the Sell-Side – we have worked on assignments where only 2 hours have been given on-site – mainly from the back of a vehicle pointing out where each piece of equipment is. This approach is of no value to the Buy-Side and will create the impression that there is something to hide, thereby generally lowering the value that can be ascribed to the assets.

Following on from the site visit, the full Due Diligence report can be completed, to assist the Buy-Side with their valuation of the business.

Key aspects for an M and A Due Diligence

Whilst the final Due Diligence report is an extensive document detailing all aspects of the operations of the plant, some of the key aspects are as follows:

- Raw materials: Sufficient reserves of limestone and shale for the long term manufacture of clinker of the current quality. Ownership of current and future reserves must be considered as well as any obligations for the rehabilitation of the quarries and whether funds have been put aside for the future work.
- Output: Assessment of historic output from the kilns and mills at the plant. This is the combination of the throughput of the equipment as well as the reliability. Having the suitable benchmarks for the different equipment used for production at the site is critical for any credible Due Diligence.
- Limiting factor: A critical part of any assessment is the identification of the limiting factor to production at the plant. Whilst the Due Diligence should be checking on the historic performance, the Buy-Side will also want to know what the plant could produce and whether there are any quick-wins to increasing production – either through capital investment or process optimisation.
- Energy: Assessment of the fuel and power consumption of the process against well established benchmarks for the process type. Security of supply of fuels, plans for alternative fuel use and the stability of power for the plant are all of major importance.

- Final product quality: Assessing whether all products are actually in compliance with the local standards as well as what opportunities exist to reduce the clinker to cement ratio down to the limits in the standards.
 - Environmental performance: Whether the plant is meeting the current environmental limits as well as any future limits that have been announced.
 - Health and Safety: The performance of the plant in terms of lost time accidents and fatalities and whether the plant is being operated in a safe manner for all employees and contractors.
 - CAPEX: Considering the historic investment in the plant and what future investment is required both for sustaining and development capital investment as well as the level of maintenance capex.
 - Spare parts: The level of spare parts – and most importantly critical spare parts – that are part of the acquisition and that will be left with the business.
- In addition to the above areas, cost of production must be analysed – this is covered in the Valuation Model section of this article.

Key Aspects for a New Technology/Product

The key aspects for a new technology or product are somewhat different to those of an existing business, as in most cases the Sell-Side are seeking investment in a concept that is yet to reach full market potential or that is still in the development phase prior to commercialisation. In these cases, some the key aspects for evaluation are:

- Technical readiness: How well developed is the concept such that it can be scaled-up and used in commercial applications? What stage is the concept at – is it lab-scale, pilot plant, semi-industrial trials?
- Scale-up: Are there any issues that will become more apparent when the technology is scaled up to industrial applications and what are the limiting factors to the technology? Is there modularity to the concept that would allow scale-up to the largest plants known in the cement industry?
- Cost: How do the costs of the technology compare to alternatives and is it cost effective – or will it become more effective in the future with changes such as increases in the cost of CO₂.
- Competition: Are other ideas being developed such that the proposed technology will be overtaken by other ideas.

The Valuation Model

In both cases of Due Diligence, it is essential to develop a Valuation Model in order to make the offer to the Sell-Side. Often, the Sell-Side will propose a valuation model for the Buy-Side to use. However, we have found that the provided model is often extremely difficult to use in terms of analysing how proposed changes and investments in the business filter through to the bottom line; in addition, the Valuation Model tends to be extremely optimistic in areas such as improvements to throughput, reliability, fuel and power consumption etc., which then produces a very favourable forecast profit.

There is generally sufficient information provided in the dataroom to produce a simple operating cost model for the plant and we would generally produce this by calculating the cost of the clinker (fixed and variable) and then converting this into the cost of the different cements produced. Producing a cost model in this way has several benefits such as understanding the margin on clinker (if clinker as well as cement is sold), what the effect of various clinker and cement related projects will be on profitability and how additional future costs such as CO₂ taxes will affect the bottom line.

Once the operating model and the forecast profitability has been calculated, the other elements such as the required forecast capital investment in the business can also be added into the model to complete the valuation model.

Multiples of earning and the “We want it” factor

Valuations of cement businesses (like many other sectors) are generally based on a multiple of profitability – with industry averages around 8 to 10 times EBITDA, although multiples of 12 times and beyond have been seen (which often resulted in the poor financial performance referenced earlier in the article). Other factors also come into play – for example if the lifetime of the quarry is low, then we would expect that valuation is lower than the multiples that are mentioned above.

However, we also find that there is also often a “We want it” factor involved – when the company is determined to buy the asset. This may be due to there being compelling market reasons for ensuring that the assets do not fall into the hands of a competitor or entering a competitors market to fend off moves in other countries, capturing limit raw materials resources in a certain country or other strategic reasons. Within this category we cannot also ignore the ego of CEOs wanting to build there companies and their status, as well as their annual bonus. However, whatever the reason for the “We want it” factor to come into place, companies should use caution in overpaying for assets and overstressing their own resources which can end in disaster, with the company becoming a target for takeover themselves further down the road.

Summary

The Due Diligence of any cement company or a new technology/product in the cement sector must be completed in sufficient detail to fully understand the business and any associated risks and liabilities. However, as well as looking for the negative points with the business, the skill of the Technical/Operational Advisor involved is to also identify opportunities for profitability improvement either through process optimisation or capital investment. The Technical/Operational Advisor should be the focal point for all of the other Advisors involved in the Due Diligence process in order to support them in understanding the business that they are evaluating.

KILN OPERATIONS OPTIMISATION

Kiln operators have one of the most important jobs on a cement plant and one where their actions can have a real-time impact on the profit and loss of the plant. They affect the kiln output, fuel and power consumption, clinker quality, plant emissions and the life of the refractory. But cement plant owners rarely invest in training, development and coaching of their operators to improve profits – JAMCEM can provide these services with its systems and kiln master burner services

PADS ASSESSMENTS

Desktop assessment of plant performance, limiting factor analysis on kiln output and gap analysis on fuel and power consumption

OPERATING COACHING

Bespoke training course for your plant and process type with JAMCEM specialist covering chemistry, kiln control loops, cooler operation and optimisation and kiln troubleshooting

OPERATING COACHING

Dedicating mentoring and coaching of operators in the kiln control room - side-by-side training of your operators to improve skills levels and understanding of the pyro-processing system

INDEPENDENT CONSULTANTS FOR THE
GLOBAL CEMENT INDUSTRY

Future trends in managing cement plants

Sanwar M. Mishra

Ex-UNIDO Consultant, posted at Vienna, Austria

Abstract

The move to digitalization of businesses cannot be ignored for long. Now, robots are entering in many areas of human activity like, offices, factories, transportation, hospitals, hotels and even the military warfare as robot soldiers. We have to seriously think over the issue for survival. What robots can do on work floor, ERP (Enterprise Resource Planning) cannot. ERP is confined to the paper work and not on the shop floor. This article covers how to enhance the productivity of cement plants under the forthcoming trends in digital technology, management methods, application of artificial intelligence etc. Focusing on ERP as a tool to improve operations will no longer be sufficient. It is here that management solutions are redefining the digital backbone of organizations

which are keen to innovate and succeed in a volatile, uncertain and complex market. Quality Standards demand consistency in quality, safety to promote active trade across various geographies.

Cement industry is a vital part of the economy of a country, providing employment to more than a million populations. Cement is a bonding agent that holds the concrete together and is therefore very important for meeting economy's needs of housing and accommodation and necessary infrastructure such as roads and bridges, schools, hospitals etc. Hence, this is one of the primary elements of the infrastructure of the country. It plays a pivotal role in financial progress and welfare of the country.

Keywords: Automated Dealer Management System, Digitalization, Pyroprocessing, ERP, Robotics, Energy efficiency

Increase in Population Increases Cement Demand

Today the world population stands at 7.6 billion. It will rise to 9.7 billion by 2050. About 2.5 billion people are expected to live in cities. This results in growth of urbanization thereby increasing the demand for solid urban infrastructure. These changes in world population will directly impact the production requirements placed on the cement industry. Global cement demand is set to grow 12-23 per cent by 2050. To achieve these global emissions targets of CO₂, and the required energy reduction in cement production, new policies and investments are needed.

CO₂ Emissions

The two most important challenges facing the industry are a pressing need to reduce CO₂ emissions and improve energy efficiency. It involves the use of low carbon fuels and energy reduction methods. The use of other fossil fuels such as biomass, on the other hand, can be an effective fuel substitute, producing CO₂ emissions that are about 20–25% less than those of coal.

Every ton of Ordinary Portland Cement that is produced releases on average a similar amount of CO₂ into the atmosphere. Improved production methods and formulations that reduce or eliminate CO₂ emissions from the cement manufacturing process are thus high in demand.

A large fraction of the CO₂ that is released in the production of Portland cement is from the calcination process. A byproduct of the firing of calcium carbonate and silica in a rotary kiln produces calcium silicate (clinker) and carbon dioxide. A more permanent solution to achieving carbon reduction is to use different raw materials and/or different manufacturing processes. These are subjects of major research initiatives worldwide. The company- C\$A cements use limestone as one of the raw materials in their production but offer a 20% reduction in CO₂ emissions by requiring a lower kiln firing temperature and therefore burning less fossil and fossil-derived fuels. The production of C\$A cements in operational plants is possible as the manufacturing process is the same – its use in China. C\$A cements have been identified as being more expensive.

A digital transformation in a gradual and step-by-step manner is suggested. It gives a better grip on operations control. Automation serves to be the central nervous system for the entire cement factory. Automation is usually considered the brain that collects data from a network of sensors, instruments, and drive systems, which then put this data to good use by automating cumbersome processes.

Equipment Monitoring & Predictive Maintenance

Using retro-fitted / factory-fitted sensors (any of the various types like Vibration, Light, Sound, DGA - Dissolved Gas Analysis, Viscosity, etc.), operators can instantly detect the source of their problem. This reduces inspection time and ordering time. In other words, the turnaround time of faulty factory equipment is reduced, which leads to saved costs and time. The following graphic representation better describes the situation.

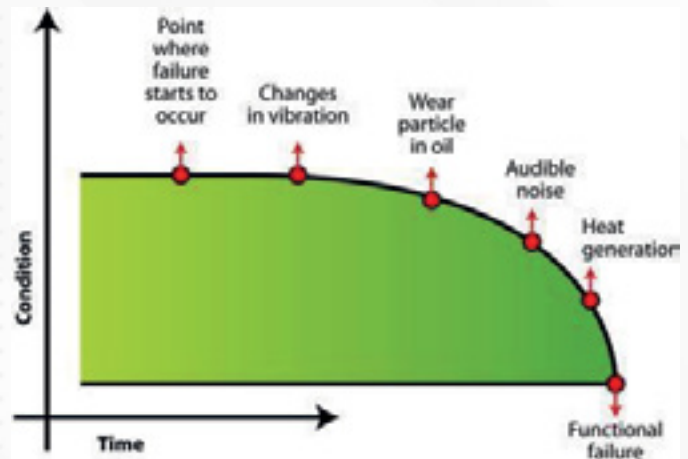

Towards breaking and re-lining required as periodic kiln maintenance, use of remote controlled robots is illustrated.



A demolition robot working in a kiln is remote controlled.

Predictive Quality & Process Control

Cement production is a process with 3 major phases :

- Raw material crushing and grinding,
- Clinkerization /burning of raw material
- Grinding the clinker to get cement

An illustration of grinding mill explains the relevant components as follows.

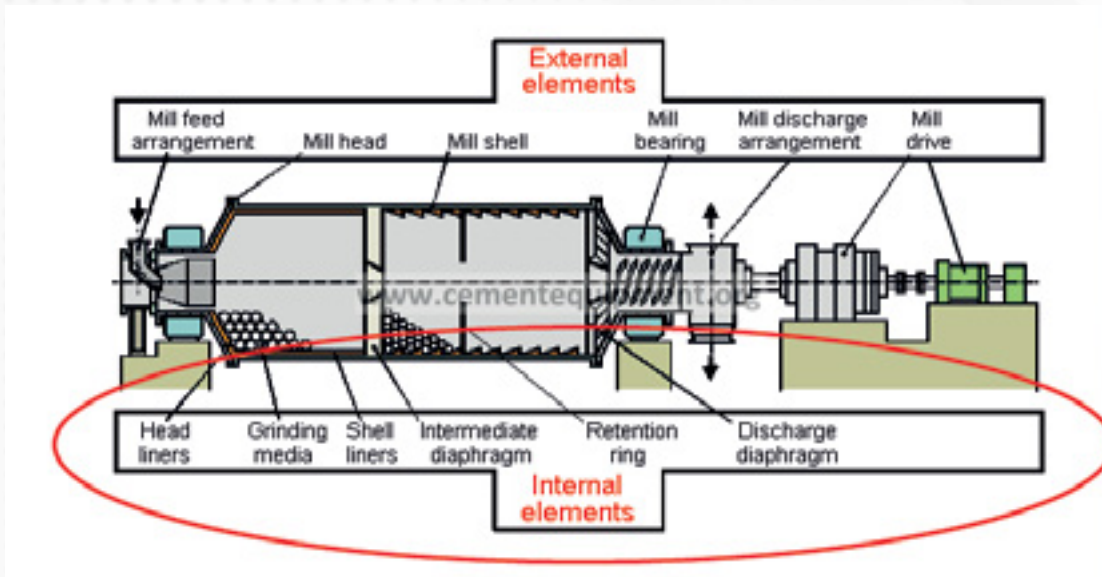

There are a lot of parameters:

- Speed of the mill,
- Mill temperature,
- Clinker feed temperature,
- Grinding duration, etc.

They make the process fairly complicated. Advanced predictive systems can be used to detect variability across these parameters. It will be useful if they can get hold of accurate data with the help of smart systems, which will help them to optimize their production operations briefed up as follows.

Quarrying

The production of Portland cement begins with the quarrying of raw materials. Most cement plants are situated near a limestone quarry to minimize transportation costs. Quarrying limestone involves drilling, blasting, excavating as well as crushing, screening and storing. The raw materials are milled together to achieve the right composition before being sent to the kiln for pyro-processing. Only the operation of machinery is responsible for CO₂ emissions when quarrying for raw materials.



Pyroprocessing

Cement clinker is made in a rotary kiln, or long cylindrical rotary furnace that turns around once or twice every minute. Temperatures are generally around 1400–1600 °C, and energy demand varies depending on the manufacturing process. The material undergoes the process known as calcination inside the kiln after all moisture is evaporated out, about a third of the way down the kiln.

The end product size ranges from dust to big lumps of calcium silicate or clinker. For CO₂ emissions in kg per kg cement produced for various fuels and various clinker/cement ratios assumed electricity use is 0.38 MJe/kg of clinker; the average emission factor of CO₂ of electricity production is 0.22 kg/MJe; fuel use is 3.35 MJ/kg of clinker (dry process) and 5.4 MJ/kg of clinker (wet process)). It should be noted these figures assume that no CO₂ penalty is attached to materials such as slag or fly ash and some may argue they are therefore highly artificial, erring on the optimistic.

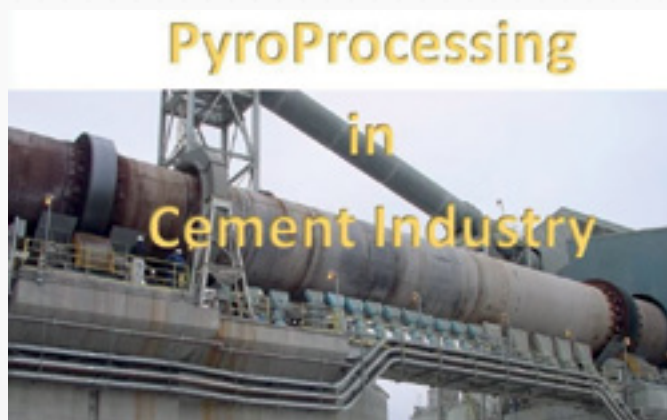

Grinding

The lumps of clinker are ground up with calcium sulfate di-hydrate (CaSO₄·2H₂O) or gypsum or active anhydrite to control the rate of hardening or the setting time (gypsum is also used to make Plaster of Paris, a commonly used rendering plaster). Usually about 2–10% of the ground-up Portland cement is gypsum. The final product, OPC cement is used in various ways, primarily to make mortar and concrete, cinder or cavity block.

Connected Logistics

In cement plants, the raw material and the finished product are highly reactive in terms of responding to atmospheric moisture, heat, impurities, etc. The transport of these materials mostly happens via road using trucks. Having a comprehensive understanding of each product unit and the vehicles that they are in is the key to having control of supply chain.

Vehicle telemetric solutions can help monitor the location of each vehicle in the fleet, the payload carried by each vehicle, and the vitals of your crew members. They also offer help in routing vehicles to their destinations and interface with factory ERP systems to give ETA and thus reduce the TAT of vehicles once they reach the factory gates.

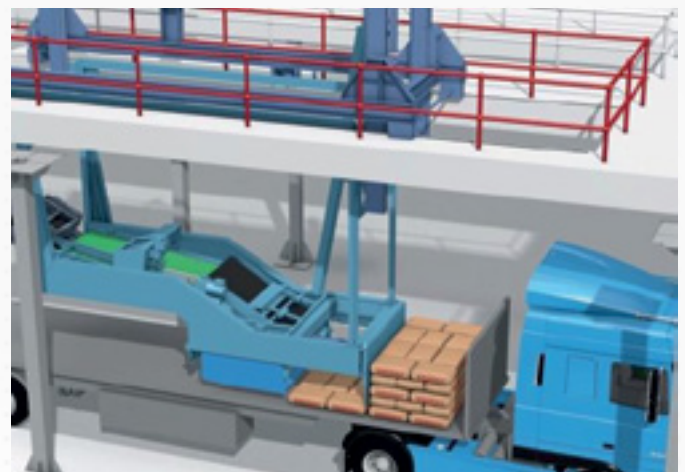

ERP System

It is the advanced enterprise application assembly and delivery platform, on Cloud enables you to get a 360-degree view of your business, anytime, from anywhere by putting all your business functions on to one single platform on the Cloud and automating and integrating them, end-to-end. With this unified view of business, you can drive innovation across the value chain, improve efficiency, and reduce costs and time to market. The entire suite of product is accessible over the Internet, which gives you the freedom to access information from any part of the globe at the click of a browser button, whether from a laptop, a PDA, mobile phone or a tablet.

Different Features of ERP Software

ERP software can differ depending on the package you purchase and the provider. ERP software should offer the following modules:

Accounting: Manage all financial reports in the same interface, such as purchase orders, expenses, sales reports, payroll, etc. This makes it easier to monitor cash flow and revenue and determines how money might be better spent or how you can reduce the burn rate.

Inventory and Warehousing: If the inventory or warehouse processes, ERP software needs to be able to integrate those operations to better track and manage goods. This makes it easier to see how much inventory is available, what inventory is going out for delivery, what inventory is coming in from which vendors and more.

Carefully monitoring and tracking these processes helps protect a business running out from of stock, mismanaging a delivery and other potential issues.



Simulation

Advanced simulator programs enable a realistic reconstruction of the behavior of a cement plant. Technologies like 'digital twin' offer virtual commissioning, operator training. It allows monitoring the plant behavior by changing the process parameters before launching into real production. For a typical cement company, all this translates to increased safety, reduced costs, and better overall efficiency. Such simulations also offer avenues for training the company's employees by replicating real-world problems and analyzing how various solution approaches to these problems differ.



In this age of Artificial Intelligence and AR & VR (Virtual Reality), simulation is not new to the world. Simulation is a process that has the potential to enable us to determine the end-result of a task before performing it, eliminating all the risks out of it.

In simple words, presentation of the real-world operation, incident, or an action on a computer is "Simulation." To elaborate further; the process of creating a model of a proposed system or operation is known as simulation.

For example, using simulation software, one can prepare the model of a building and represent it in the form of 2D and 3D giving the exact idea about how the building will look after its real construction. How much manpower would be used in the construction, and what would be the total cost behind the construction. It solves many unexpected or currently occurring or likely to occur problems during the actual construction process.

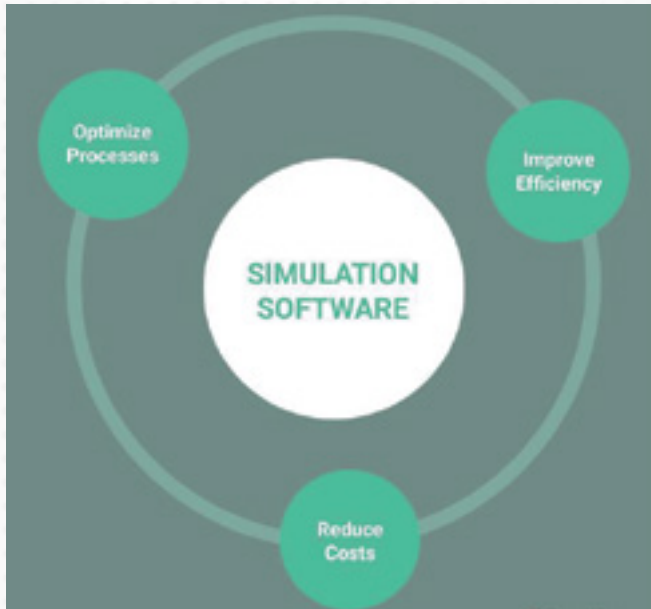

The simulation software helps us in foreseeing the potential risks involved with the particular operation before actually taking it into action. Being extremely useful; it is being used by many industries these days. Let us understand the factors through which the problems in the process or any system can be detected and resolved.

Types of Simulation Software

The simulation software can be categorized based on the functionality it performs. Some of the leading types of simulation software include:

Risk Analysis

A new project implemented or a change in a process has an impact on the profitability of a business. This type of simulation software is built on mathematical models which identify the potential risks and uncertainties using probability distributions. It gives a complete understanding of the future possible threats to the business in case of a new idea or project is executed.

Agent-Based

The term “agent” here means equipment, people, or practically anything else which can impact the processes of an organization. For example, think of the impact a new machine can have on the overall production of a manufacturing unit. Agent-Based simulation software can help you in extracting the accurate insights and responding smartly.

Discrete Event

The discrete event type of simulation software helps in detecting the specific events that occur due to your specific business process. For example, the increase in leads was due to a new advertisement of your company published. This type of simulation software can be used for a diverse range of organizations to help them scale and stay competitive.

System Dynamics

System dynamics doesn't refer to the new product launch or any other event having an impact on the profitability of the business. It refers to the entire system, which can affect the processes of an organization. For example, simulation tools based on system dynamics can foresee the consequences of discontinuing a product line on the overall business.

Digitalization

It spans across all the areas of an organization – Marketing, Operations, Human Resources, Supply Chain, Logistics, Shop floor, etc. Such a step will enable true information connectivity and will reap several benefits.

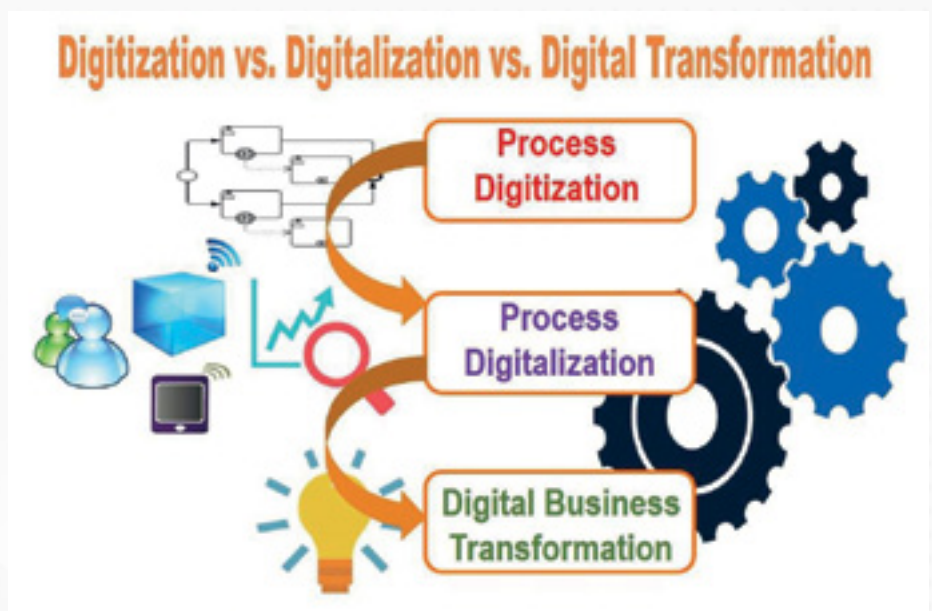

Robotics

Robotics is a branch of artificial intelligence. Computer science and engineering are concerned with creating robots and devices that can move and react to sensory output. Robots are widely used in factories for precision jobs e.g. welding, machining, riveting etc. And robots are working in situations which are dangerous for humans such as defusing bombs, handling toxic waste.



More Robots, More Workers

Contrary to popular belief, robots are not replacing workers. Robot-adopting firms become so much more productive that they need more people to meet the increased demand in production. Non-adopting firms became less productive, relative to the adopters. They lost their competitive advantage and, as a result, they had to lay off workers.

The issue is about how do you leverage technology better to become more productive, to become more competitive? And how do you change your strategy by deciding which operations to robotize?



See robots don't need any tea or coffee, water bottles, work-break etc.

Robots Render Some Managers Obsolete

Certain kinds of managers become superfluous as businesses increase automation, according to the study. The drop is simply an effect of modern technology. As different tasks and processes are automated, human error is drastically reduced. So, too, is the need for close monitoring of that work by managers.

Although robot adoption results in increased employment, the increase is not uniform across skills. Low-skilled workers, such as box packers, and high-skilled workers, such as engineers, grow in numbers, but middle-skilled workers become endangered.

When we see a huge decrease in middle-skilled work and an increase in those extremes — high- and low-skilled labor — it means the type of managers we need to manage this new workforce will be different.

Someone who supervises low-skilled workers can manage a lot more people when the firm brings in robots because of the standardization and efficiency. But the change is more ambiguous for managers of high-skilled workers. Those employees are typically responsible for innovation, rather than operations, which is harder to measure.

Highly-skilled professionals are very good at what they do, better than their managers. They don't need managers to tell them how to do their jobs or make sure they arrive to work on time. Managing high-skilled workers is much more like coaching or advising. Managers advise them to help them to achieve the best they can at work, and that kind of skill is very different from supervising work.

The Revolution Is Inevitable

The robot revolution is "inevitable" given the leaps in artificial intelligence, machine learning, and other technologies rapidly transforming the workplace. We have to accept the change and explore strategies to maximize the benefits. For example, robots were associated with greater use of performance-based pay because automation reduces variance. In other words, it's easier to meet production quotas when robots are on the job. Robots also reduce workplace injuries.

Business leaders should be mindful of their low-skilled workers. As a company automates and the middle-skill level shrinks, those entry-level workers lose upward mobility. In our old paradigm, we don't expect people to stay on those jobs forever. But now we notice that the career ladder is broken. There is no middle skill to go to. There are no supervisory jobs to go to. That means that the contract, where there is an implicit understanding that you will move up eventually from your low-skilled work, needs to be revisited because it's changing.

Energy Efficiency

Professionals engaged in cement plants today want innovative solutions that will help improve plant utilization and optimize processes & reduce energy consumption.

The energy consumption is based on:

- Type of process
- Type of equipment
- Operating efficiencies
- Local and national legislation
- Technology the plant uses

Energy management

The concept of energy management is to reduce the loss of energy and cost of production. It can be done in various ways, some of which include:

- Optimization of the cement production process at every level
- Optimal planning of production schedules
- Energy audit and analysis
- Usage of low-cost fuel or alternative fuel
- Recovery of heat and utilization
- Reduce specific power consumption



The companies must employ cutting-edge technology solutions. The industry can think of the following:

- Installation of sensors/weighing systems
- Smart meters for accurate measurement
- Data acquisition from shop floor to board room
- Real-time data with a transfer rate of milliseconds
- Process data storage for getting business insights with AI technologies
- APC (Advanced Process Control system) Installation
- Remote access for online monitoring

An ERP specially designed for the cement industry would provide the following benefits to further optimize the plant and business operations:

- **Data Visibility:** With easy-to-understand, real-time information at their fingertips, decision-makers / plant managers can make more informed & actionable decisions that will impact energy consumption.

- **Planning can be updated in real-time:** Real-time data and historical data would mean improved visibility into inventory, grinding processes and other crucial aspects, and that would help in planning and predicting outcomes. You can save resources with careful planning, resulting in an efficient cement plant.
- **Maintenance schedules can be precisely timed:** With information on equipment running, and other indicators such as vibration monitoring, maintenance schedules can be timed well. An additional advantage of this would be less equipment downtime.
- **Harnessing advanced and integrated process control systems** can improve productivity. You will have control over your processes and will have a better chance at improved yield, lowered expenses etc.
- **Reduced Energy and Heat Consumption:** Optimized production processes in a cement factory will lead to reduced energy and heat consumption.
- **Overall improved efficiency** can be achieved.

Conclusion

Manufacturing processes in cement production have been and continue to be optimized and automated, using the best technologies available to reduce cost, emissions, economize power and increase productivity. This has led to incremental reductions in Green House Gas (GHG) emissions and has also reduced the industry's employment levels. Review and update of the manufacturing process lie firmly within the domain of cement manufacturers, cement production equipment manufacturers and cement plant designers. Approach of robotics will change situations in future. Energy management is an existence essential along with CO₂ emission reduction target.

Sanwar M. Mishra, Ex-UNIDO Consultant, posted at Vienna, Austria

Address:

Mr. Sanwar Mal Mishra

98, Ganeshnagar, Motidungri, Jaipur-302004, Rajasthan, India

Phone: +91 8279268558

Worked with cement plants- Satna Cement (India) Oman Cement (Oman) Fujairah Cement (UAE), Chilanga Cement (Zambia) and J K Cement (India)

Case Study

Plug & play slip ring motor configuration for a cement mill

Carbon brush selection makes all the difference

Mathis Menzel

CEO of Menzel Elektromotoren, Berlin, Germany

Large slip ring motors are very much in demand in the cement industry. A motor manufacturer finds that the right choice of carbon brush is essential. Various factors must be taken into account, from the application to the site and even climatic conditions.

A cement plant operator in the United Arab Emirates experienced problems with the vertical mill's main motor. The industry giant looked for an immediate replacement rather than facing the risk of a lengthy production standstill. At that time, Menzel Elektromotoren, an experienced and trusted partner of the cement industry, was just building two new motors in the right performance class.

The German motor manufacturer keeps an exceptionally large inventory and can usually assist customers immediately. Delivery would take eight weeks, which is a huge improvement on the six to the nine months it usually takes to build a large-scale motor to order. As it turned out, Menzel got the order as no suitable motor was available sooner.



Image 1, 2: Menzel adopted the old motor's (left) tilted terminal boxes for the new motor (right) to enable plug-and-play installation in cramped conditions

Tough job

Menzel also ticked all the other boxes to qualify as a provider. The company supplies motor solutions for all kinds of cement applications and has a deep understanding of the industry's particular needs. Motors for cement plants face several challenges: continuous use, maximum performance requirements, dusty environments, often combined with extreme ambient temperatures. The motors must provide high starting and breakaway torques and be able to withstand severe mechanical stress through vibrations and sudden load surges. When it comes to refitting an existing installation, motor suppliers have to cope with restricted space and be flexible in adapting standard solutions to fit each individual installation site. This was the case in the current project, and because of the pressing schedule, the client specified plug-and-play installation, necessitating the motor builder to work with the utmost precision on various adaptations. Importantly, unlike most suppliers, Menzel offers both squirrel-cage and slip ring motors in the upper output and size range. The client requested a slip ring motor, a very challenging design especially because the motor was to be deployed in a cement plant, as will be shown below.

No brush for all weathers

Slip ring motors are still very common in the cement industry making them a desirable field for motor manufacturers. However, though many have tried, few have succeeded. Menzel found that the right selection of carbon brushes is what beats competitors. Carbon brushes are wear-and-tear parts mostly composed of

graphite and copper. Copper provides high conductivity. Carbon serves as a lubricant, creating a patina on the slip ring. A high degree of engineering expertise is needed to define a brush grade mixture for each application or motor. The more that is known about the environmental conditions at the very start assists in the selection of the best brushes. Menzel equipped the current motor with brushes suited to the hot, dry desert climate, with water molecules enclosed in the brush face. Other motors delivered to places with a humid tropical climate, to very cold places, or high altitudes need other special compositions. Indoor or outdoor use, sea air, sulfurous or explosive atmospheres, abrasive media in the cooling air are factored in. The available power infrastructure with more or less dependable load uniformity must also be taken into account. There is a sure way to find out whether the right choice was made. The motor documentation advises the operator about the brush exchange interval. If they need to be exchanged much earlier, there is probably something wrong. Menzel will check the installation site, analyze the carbon dust, and provide more suitable brushes. In almost a century of manufacturing industrial electric motors, Menzel has built up extensive know-how about carbon brushes that exceeds even that of renowned specialized brush manufacturers. In the past, the company has been called in to replace brushes by one of the leading brands. In contrast, some of the biggest motor manufacturers have gone back to offering only squirrel-cage motors to cement plants, because they could not get the brush selection right.

Image 3: Different applications and climatic conditions require different carbon brushes; getting the composition just right requires expert know-how

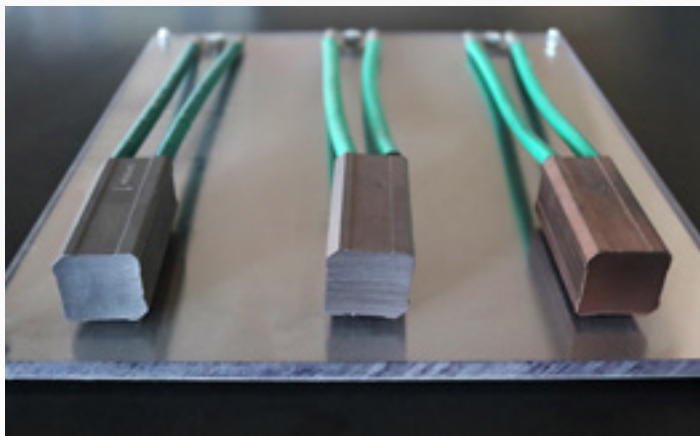



Images 4, 5: A roomy slip ring compartment, separated from the motor interior and with large service windows on both sides enables easy brush exchange in dusty environments (brush system shown before installation)

Slip ring motors going strong

Slip ring motors are still the preferred choice of many cement plant operators. Compared to squirrel-cage motors, they offer considerable advantages in exceedingly dusty environments and are thus particularly suitable to drive mills, crushers, augers, and conveyor belts. The price difference for large-scale motors is also considerable. Slip ring motors, which are started up with a liquid-resistor starter and produce the full starting torque from standstill, present a cost-efficient solution. By contrast, squirrel-cage motors need power electronics to overcome the high mass inertia typical for applications such as mills, crushers, and conveyor technology. Such variable frequency drives (VFD) are very pricey in the high-output range and need elaborate protection and cooling measures because they are also susceptible to dust. On balance, slip ring motors, if properly maintained and sized to fit the application requirements and thus achieve good energy efficiency, are the superior choice for cement mills in terms of TCO (total costs of ownership) as well as availability.

Menzel slip ring motors feature two large maintenance windows, allowing comfortable access to the slip ring chamber, which is

separate from the actual motor, in order to prevent pollution. The manufacturer selected a slip ring motor from their MEBSSL series for this cement mill. The series' enclosed IC 611 cooling system with an air-to-air heat exchanger that is fully separated from the motor housing ensures optimum dust protection and thermal properties.

The weld-iron housing with an integrated foot plate provides maximum torsional vibration resistance and optimal cooling characteristics. The reliable and durable bearing construction and the overall highly robust motor design ensure high availability and a long service life. Due to the series' excellent power density Menzel could select a smaller, more efficient motor than the original. This motor series generally boasts a compact design, high energy efficiency, minimal running costs, low maintenance costs, high load capacity, and quiet running due to a precision-machined stator lamination. The motors feature integrated condition monitoring with PT100 thermometers installed in the winding and bearings as well as mechanical shock pulse measurement (SPM) taps for recording vibration values.

No off-the-shelf motor

Even though Menzel had a suitable motor in production when the order came in, several adjustments were necessary. The client requested plug-and-play replacement of the original motor, which is highly unusual for this output range. Manufacturers typically offer various sizes in their motor series and different accessory options. Menzel's approach stands out in that nearly every motor is unique. The family-run company prides itself on catering for all customer requirements and preferences, sourcing accessories externally if they do not have them in stock or manufacturing them from scratch. Accordingly, the in-house welding shop produced a new foot plate to adapt the shaft height to that of the original motor. The plug-and-play configuration of the electric connections proved especially challenging.

The terminal boxes had to be installed in the same position and angle as the old ones. To get the bending angle of the thick cables just right and to connect them at the set position in very restricted space, the team even built a 3-D model. All they had to work on were mobile phone photos and technical drawings of the old motor. They shortened the shaft, machined it to a smaller diameter to fit the vertical roller mill, ran an ultrasound check to detect any microcracks, and got it certified by an independent body. The client witnessed final testing at Menzel's Berlin headquarters, including a no-load test at rated voltage, vibration measurement, a short-circuit test, and accessories testing. The finished motor system including the 6060-kW motor, coolers, fans, and special terminal boxes weighs 32.65 tons.



Image 6: Menzel shipped the dismantled motor within 8 weeks of the order being placed

About Menzel Elektromotoren

Menzel Elektromotoren GmbH has been manufacturing and distributing electric motors since 1927. The medium-sized company specializes in the delivery of large electric motors, including special models, within the shortest possible time. The product range comprises high and low voltage motors, DC motors, transformers, and frequency inverters. Services include motor production and short-term adaptation of stocked motors to application-specific requirements. In order to ensure fast deliveries to the customer at all times, the company maintains a very extensive inventory including more than 20,000 motors with a maximum performance of up to 15,000 kW. Qualified engineering, experienced staff, and state-of-the-art production and testing facilities help Menzel provide excellent reliability. Menzel operates subsidiaries in the UK, France, Italy, Spain, and Sweden, and cooperates with numerous partners worldwide. The company is currently building an all-new headquarters and spacious modern motor factory in Hennigsdorf on the outskirts of Berlin and will have completed its move there by early 2024.

Contact:

Menzel Elektromotoren GmbH

Mathis Menzel

Neues Ufer 19 – 25
10553 Berlin
Germany

Phone: +49 . 30 . 349 922-0

Email: info@menzel-motors.com

Internet: www.menzel-motors.com

Primetracker new technology for appropriate aligning

Easy to install, reliable, controls even for reversible belts

New technologies developed have allowed for a much simpler example of a mass imbalance activated tracker. This design uses a flexible coupling in the centre pivot, rather than a fixed axis shaft at 45°. This allows for completely 360° free motion about the centre of the tracker, which has created an inherently reversible design. The steering of the roller is activated by additional mass and friction to one side of the roller, which drags the roller drum forward and steers the belt back to centre. Results in the field have shown there is no downside to this design compared with the fixed axis design, and it has been found that the rubber coupling is a more reliable unit, due to its simplicity and given it is not affected by contamination like a conventional greased bearing.

Bulksolids-portal

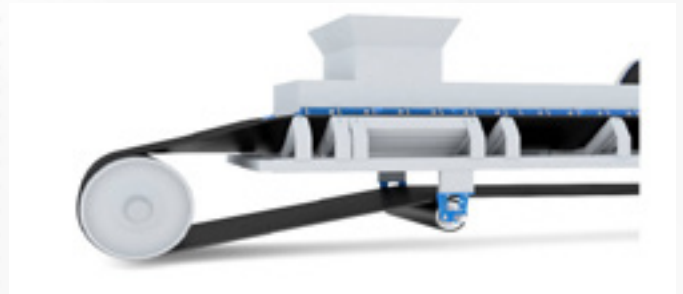
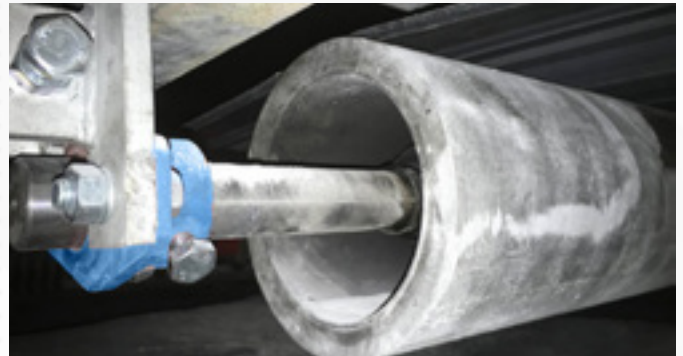

Envea presents the new LAS 5000XD in-situ laser (tdls) gas analyzer

The LAS 5000XD cross-duct laser gas analyzer offers fast response time, robustness and is calibration free, for measuring an extensive range of parameters such as NH₃ + H₂O, HF, CO + CO₂, O₂, HCl + H₂O, CO₂ + H₂O, etc.

The new TDLS (Tunable Diode Laser Spectroscopy) LAS 5000XD gas analyzer comes in various models for measuring an extensive range of parameters such as NH₃ + H₂O, HF, CO + CO₂, O₂, HCl + H₂O, CO₂ + H₂O, etc.

It has been designed to offer robustness, fast response time (1 s) and high accuracy measurement in harsh environments. The analyzer is calibration free, doesn't require a sampling system and provides a large and dynamic measurement range from ppm to %. It offers real-time communication between receiver and transmitter units and an embedded web server.

In addition, the LAS 5000 XD includes a specific feature for managing outside path interference.

Indeed, thanks to ClearPath, interference of relative humidity, O₂ or CO₂ is removed from the purging areas. This guarantees high accuracy measurement of H₂O, O₂ and CO₂. As a consequence, N₂ and dry air purge are not needed. Operator's benefits include low maintenance, process optimization and reduced total cost of ownership.

The instrument is adapted to a wide range of applications for CEMS and process, such as:

- Ammonia slip control (DeNO_x)
- Combustion control
- HF emission control in aluminum plant
- HCL abatement control
- Ethylene cracking furnace control
- HCl level in semiconductor production
- Ammonia concentration control in pet food and fertilizer plants, etc.

Examples of measuring ranges:

- NH₃ + H₂O: 0–10 ppm / 0–5000ppm +0–5 % / 0–40 %
- HF: 0-3 ppm / 0–500 ppm
- CO + H₂O: 0-50 ppm / 0-1% + 0-5 % / 0-40 %

The LAS 5000XD features a full package of optional accessories ensuring a smooth and efficient operation (Thermal Shield, weather protection covers, etc.).

Bulksolids-portal

SIWERTELL smartview

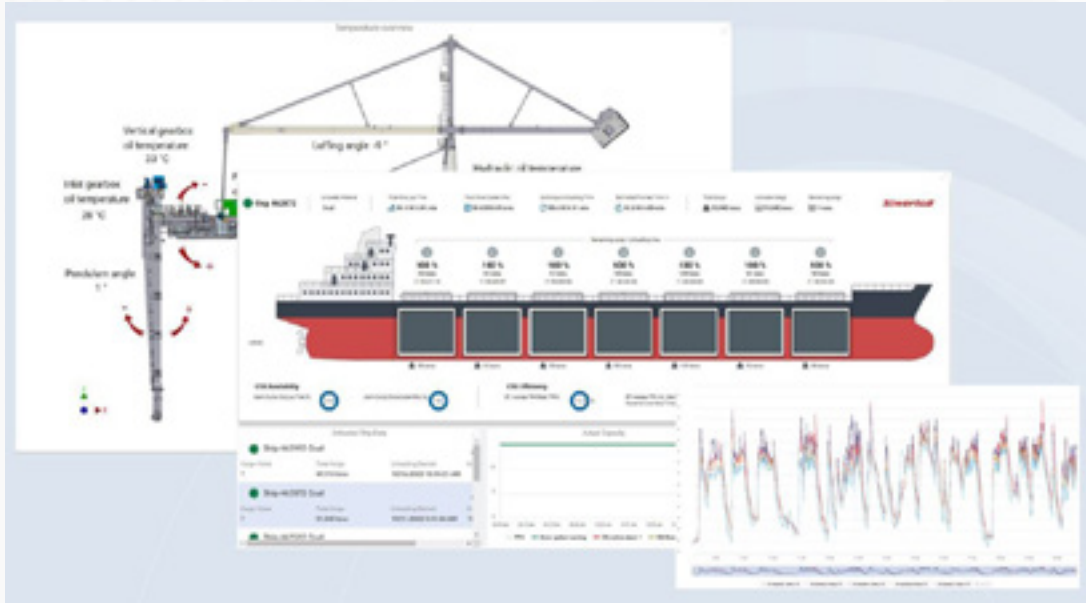

Siwertell Smartview is designed to optimize the productivity and profitability of dry bulk handling operations through enhanced data visualization and analysis.

The power of knowledge

The most important aspects of data collection are what is done with it and how it is presented. Through Siwertell Smartview, operators are able to access live and historic data, empowering them with accurate knowledge, enabling smart management decisions through greater operational awareness.

Siwertell Smartview is a cloud-based, next-generation industrial Internet of things (IIoT) tool. It collects data during unloading and loading operations, which provide a detailed analysis of equipment performance, availability and reliability. Automated report functions ensure that operators are able to make the most of this information, including operational performance data and individual vessel reports, and details about any equipment downtime.

Learning from the past

Siwertell Smartview is also able to identify areas that can be improved, enhancing efficiency, minimizing downtime and a terminal's potential profitability. Other parameters that can be analyzed include historical equipment availability and performance, and component data collection.

Historical data analysis enables performance studies over different vessel types and sizes or commodities. Furthermore, reviewing the performance of different shifts can identify possible training needs. All enable the continuous improvement and optimization of our customers' terminals.

Enhanced, scalable service

As well as operational optimization, Siwertell Smartview will be able to provide comprehensive information about maintenance requirements. This includes everything from monitoring service intervals and remote support with assisted fault-tracing, up to a full service update. The tool tracks component-level data, analyzing which parts need service attention and when.

Siwertell Smartview: key benefits

- Increased productivity
- Enhanced in-house awareness
- Rapid identification of operational bottlenecks
- Detailed automated reporting for servicing and operational performance optimization
- Training opportunities identified through shift performance review

Remote support will:

- Enable the remote analysis of equipment and performance
- Result in quicker response times, lower service costs and access to Siwertell experts
- Enable flexible and scalable remote service support

Siwertell Smartview: overview

- Cloud-based solution for IIoT-enabled equipment
- Connectivity from personal computer (PC), tablet or smartphone
- Management overview of operation
- Live and historical data analysis
- Performance studies
- Automated reporting
- Analysis of terminal performance, reliability and availability
- Maintenance management

Siwertell Smartview is planned for a phased launch in 2023, starting with new equipment deliveries. Ultimately it will benefit both our existing as well as new customers. Siwertell Smartview is suitable for all Siwertell ship unloaders, including port-mobile and road-mobile units, and ship loaders.

We would be happy to provide you with any further information. We can also arrange for you to speak directly with one of our dry bulk handling experts, if this would be helpful. Please get in touch if we can be of any further assistance.

Per Hansson
Sales Director EMEA & LatAm
+46 706885925
per.hansson@bruks-siwertell.com

Bruks Siwertell AB, Box 566, 267 25 Bjuv, Sweden, +46 42 85 800

CAMSIZER 3D - particle tracking reveals true morphology

The latest generation of dynamic image analyzers in the CAMSIZER series offers a groundbreaking innovation in particle characterization.



The CAMSIZER 3D enables a true three-dimensional measurement of the sample. It boasts a unique particle tracking function: the cameras capture several individual images of different orientations of the same particle as it moves through the measurement zone.

This technology ensures that the true size and shape values are recorded. Especially for the

length measurement of stretched particles (e.g. extrudates) this is a decisive advantage compared to conventional 2D particle analysis, where the particles are captured in arbitrary orientation and do not show their "true" length.

Moreover, the 3D method offers significantly better accuracy for detecting defective or broken particles.

[Bulksolids-portal](#)

REALTIME VOLUME MONITORING WITH FIRST SMART LIDAR

Blickfeld announces the delivery of Qb2, the world's first Smart LiDAR. The Blickfeld Percept software runs on an integrated computing module and provides all relevant data for volume monitoring of bulk solids.

Qb2 is based on Blickfeld's proprietary solid-state software-defined LiDAR technology, and, as an industry first, enables the capturing and processing of data on a single device, removing the need for additional computers and bringing faster insights, improved response times, and better bandwidth availability via edge computing.

Companies benefit from high-efficiency gains through enriched, actionable real-time 3D data for example in the areas of volume monitoring of bulk materials automatically fed into their IT systems like the ERP or the cloud.

Installation and maintenance costs and effort are kept low due to the on-device WiFi connectivity. Qb2 offers improved functionalities and performance parameters like enhanced adaptable field of view (FoV), detection range and scan pattern, plus higher resolution, accuracy and an IP67 rating.

The Qb2 provides real-time insights allowing companies to plan better and make data-

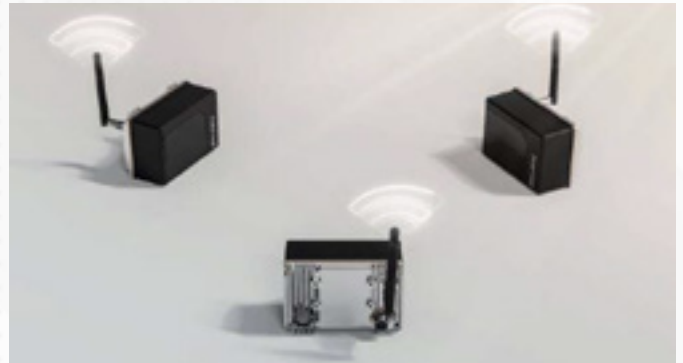

driven decisions. The technology makes the digital supply chain a reality, taking traditional, analogue industries into the digital future and improving their market position.

For those looking to source volume monitoring data, Qb2 empowers on-demand, remote and precise monitoring and management of inventory across multiple locations as well as the optimization and digitalization of the value chain. Where Blickfeld's LiDAR Cube 1 has already revolutionised stockpile monitoring processes for leading companies, Qb2 with its proprietary solid-state software-defined LiDAR technology, will provide companies with an even more powerful, versatile and cost-efficient solution.

[Bulksolids-portal](#)

SACMI Digital Decoration LAB, A new 'open platform' for digital decoration research

A SACMI priority for many years, digital surface decoration has seen its potential skyrocket thanks to the development of all-new technologies and application solutions. That potential now extends beyond ceramics to other sectors, such as metal products and packaging.

And the new SACMI Digital Decoration LAB aims to seize every opportunity. The Lab is co-funded by the 'Activity 5.1 Local competitiveness infrastructure development support' regional

tender, part of the Regional Manufacturing Projects Program 2012-2015. By expanding its equipment pool and skills set, it aims to establish a well organized engineering and applied research facility for the digital surface decoration field.

The project was launched in January 2021. Its first goal was to create a true 'industry hub' at the Casalgrande (Reggio Emilia) facility, a place where both client companies and raw material suppliers (pigments, inks, materials) can test materials on pilot lines.

There are two main ‘families’ of solutions. These are housed in an area that will also include a ‘showroom’ displaying the most recent solutions. The first, the SACMI Deep Digital line, is the gold standard in digital ceramic decoration as it can perform both wet decoration and provide an array of new grit, spray-dried glaze, material and effect applications.

The second ‘family’ in the showroom is the DMD (digital metal decoration) line. This is used to decorate the pre-cut sheets used in metal packaging, an area of keen interest to both SACMI and the wider ‘packaging valley’ region. In the latter, in fact, traditional offset decorations could be used alongside new digital decoration techniques, which are vastly more versatile when it comes to handling small batches and diversified product mixes.

Behind the ‘front office’ (showroom and pilot line) the Lab also has a prototype development and experimentation area. Again featuring upgraded equipment, this area has strengthened SACMI’s strategic ‘waveform’ research project (i.e. optimization of the electrical signals needed for proper droplet formation).

Waveforms play a crucial role in digital printing technology, on both the wet and dry application fronts. Optimization of this hitherto unexplored technological field will see the latest dry digital printers on the DDG line benefit from significantly improved quality.

Moreover, the analysis laboratory has been given an instrumentation upgrade to extend research into new fields and improve customer service.

In addition to expanding both the potential and the application range of digital printing, the project also focuses on research, development and characterization of new, sustainable materials. A good example of this is the use of ‘water-based’ inks-fluids with a low organic substance content.

This involves numerous players: on the one hand, the entire upstream part of the supply chain, such as ink and print head producers and, on the other, all potential downstream users such as ceramic manufacturers (the lab will be located at the center of the strategic ‘ceramic district’ between the provinces of Modena and Reggio Emilia).



SACMI Digital Decoration LAB therefore acts as a link between businesses, suppliers and potential customers. Yet it also works in close collaboration with universities and the regional research center network to speed up the transfer of innovation to businesses. These include the University of Modena and Reggio Emilia, other regional universities and Emilia-Romagna High Technology Network nodes/hubs with whom projects and partnerships in various fields are already under way.

Thanks to region-level co-funding, SACMI has, as part of the proposed project, also recruited new specialists (Materials Engineers, Electronic Engineers, Chemists) to lay out development guidelines and bolster the existing lab team.

Indeed, development of human resources will be one of the project’s cornerstones. For internal personnel, this will be pursued by transferring skills between young graduates/trainees and research/production personnel within the Group’s various businesses. Know-how exchange will also take place between all the former and universities (via internships and dissertation projects). The Lab also aims to provide customers with advanced, ongoing training in order to align suppliers’ technical skills with the standards required by the new systems.

Started up last December, the Lab will become fully operational over the coming weeks as the infrastructure undergoes completion.

Predicting 3D print quality from powder properties

Transitioning from ‘trial and error’ to a more cost-effective, sustainable approach with the FT4 Powder Rheometer®

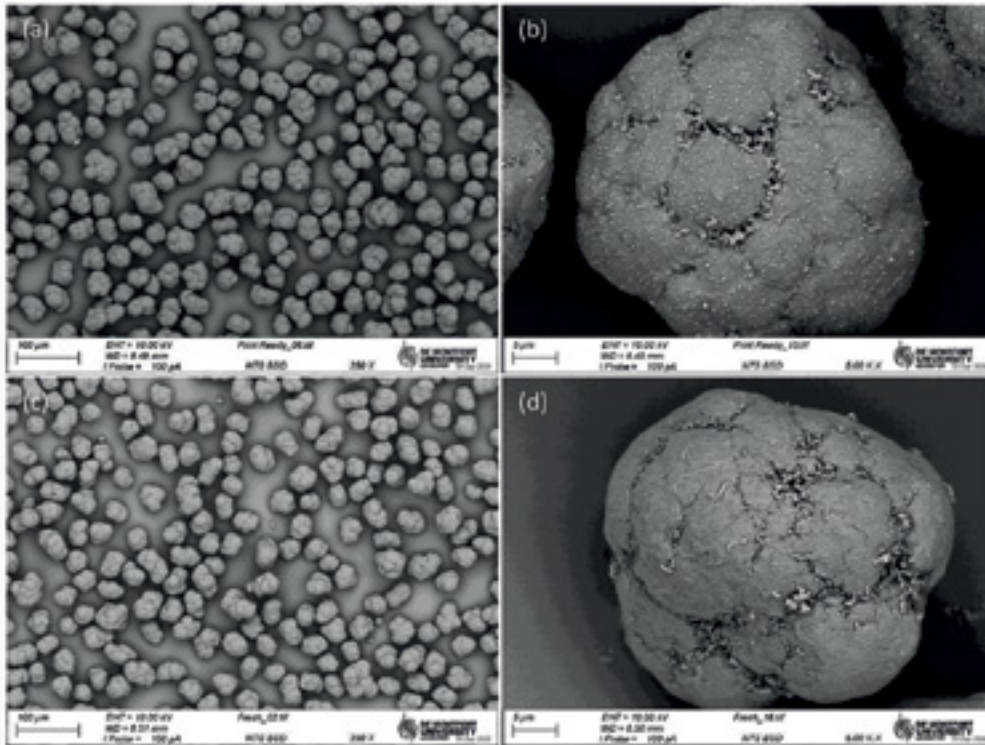

Researchers from De Montfort University (Leicester, UK) have successfully correlated the quality of 3D printed polyamide specimens with powder properties measured with the FT4 Powder Rheometer® from Freeman Technology paving the way to more cost-efficient, sustainable powder feedstock selection. Powders are currently selected for 3D printing via print trials, but these are costly, time-consuming, and wasteful. Key observations from this latest research are that the:

- quality of polyamide 3D printed specimens is dependent on the packing efficiency and flowability of the associated powder feedstocks
- packing efficiency and flowability can be reliably differentiated via the measurement of bulk and dynamic powder properties with the FT4 Powder Rheometer
- key mechanical properties of printed specimens such as dimensional accuracy, tensile strength, and surface roughness correlate robustly with polyamide powder properties measurable with the FT4 Powder Rheometer

In the study, two commercial polyamide powders of similar particle size and morphology were used to produce five powder blends for testing. Measurements of dynamic properties – Basic Flowability Energy and Aeration Ratio – clearly differentiated the blends with respect to flowability while Conditioned Bulk Density values provided complementary insight on packing efficiency. Print trials with the powder blends using a commercial Selective Laser Printing system produced samples that varied considerably with respect to mechanical properties. Observed variability was rationalized with reference to the measured powder properties and correlations were established for key properties.

Improving the efficiency and sustainability of 3D printing are essential to extend commercial application. For powder-based processes a key goal is the ability to characterise new and recycled powders to predict behaviour in the printer, as well as the properties of finished components. This study adds to the growing weight of evidence that suggests the FT4 Powder Rheometer can help to realise this goal, for both polymeric and metal powder feedstocks.

[Bulksolids-portal](#)

The new aerosol generators by PALAS

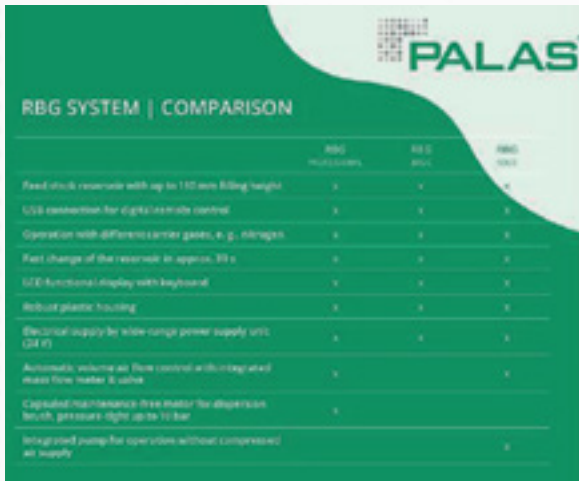

	RBG professional	RBG basic	RBG solo
Feed stock reservoir with up to 100 mm filling height	✓	✓	✓
USB connection for digital remote control	✓	✓	✓
Operation with different carrier gases, e.g. nitrogen	✓	✓	✓
Fast change of the reservoir in approx. 30 s	✓	✓	✓
12.1" functional display with keyboard	✓	✓	✓
Robust plastic housing	✓	✓	✓
Optional supply by wide range power supply unit (24 V)	✓	✓	✓
Automatic volume flow control with integrated mass flow meter & valve	✓	✓	✓
Capacitor-resonance free motor for dispersion (brush, pressure, right angle to bar)	✓	✓	✓
Integrated pump for operation without compressed air supply	✓	✓	✓

Fast. Simple. Reproducible. The RBG System. With integrated pump or pressure-proof - The new aerosol generators from Palas GmbH meet all requirements

For mass flows from 40 mg/h to 800 g/h, the three new aerosol generators RBG professional, RBG basic and RBG solo meet all current requirements in many areas - from research to quality assurance and calibration.

The feed for the storage container filled with dust or powder is provided by state-of-the-art stepper motor technology, which ensures precise feeding to the dispersing brush over a wide mass range.

The RBG professional is also designed to be pressure-resistant up to 10 bar and is equipped with automatic volume flow control. This ensures high stability of dispersion performance over a wide range of applications, even with fluctuating supply pressure.

A pump for supplying carrier air is installed in the RBG solo. This means that the unit can be used anywhere even without a compressed air supply.

All models also offer the option of remote control via PC using the Palas® RBGControl software, which is included in the scope of delivery.



The new RBG system is particularly convincing due to:

1. Flexibility:

Three models cover the whole application range

2. User friendliness:

Modern design with a large functional display and simple operations at the unit itself or via USB interface using a computer

3. Extended performance:

- Pressure-tight up to 10 bar;
- Mass flow from 0.04 up to 800 g/h;
- Up to 100 hours operation time with one material storage reservoir;
- Change of the storage vessel in less than one minute

[Bulksolids-portal](#)

Brand visibility in hd: your product. Your colours

Position your product exactly as envisioned - in sharp, high definition and lively colours that highlight your brand. Attract and inform your customers with a majestic label that values your brand, your product and your customer.

We offer the freedom to create the label that maximises your product without compromise, by printing any colour value, from any colour model, in advanced high definition. And that is not all. In addition, we bring Brady's vast label materials knowledge to bear, so that your product label, as well as your brand, present themselves unscratched and unscathed to any customer, anywhere.

Attractive & practical

Our printing capabilities bring vibrant visuals to life, and offer highly legible information, even in the tiniest of font sizes. Any data, from serial numbers to usage icons or warning signs, can be added with poise and speed. As a result, you'll be able to add the most scanner-friendly product barcodes for your partners. And in the moment of truth, you'll communicate with customers better than ever before.

[Bulksolids-portal](#)

1050, The new laboratory milling concept

With their intelligent systems engineering, NOLL Processing Technology has been a renowned partner in R&D for three decades.

With multifunctional laboratory system 1050, NOLL has set a new standard, Ulf Noll explains: "It's a concept unprecedented in the compact class. Standardized and extremely flexible at the same time, and with a purchase price of less than 100,000 €, it is more cost-efficient to operate than any other laboratory machine on the market. In engineering and construction design, user-friendliness has been our principal objective."

Air classifier or mill? – Change in no time.

1050 shows how easy multifunction in the laboratory can be. The system features two equipment options: Either working as dynamic air classifier *SeparaNo® 1050 E* or as opposed jet mill *MultiNo® 1050*. Both options operate on the same basic construction frame – and it takes just a couple of minutes to change the classifier and mill modules. Purchased with air classifier only, the system is upgradable anytime with a *MultiNo®-M/S/M* module – or vice versa. Both modules allow inert gas operation (argon, nitrogen).

Finally. A mobile system that gets through your door.

Ultra-compact design, easy to use and clean: The 1050 system is mobile, gets through any standard door (200 x 80 cm) and has an exceptionally large 10-inch touch panel in its housing desk. The users' manual can be integrated into the touch panel, making the system work like a smartphone.

No more transfers: Fines filled directly into your sample container.

Another unique feature of 1050: After fractionizing or milling, the fines are directly filled into standard containers, e.g. sample boxes and jars, ranging from 0.5 to 5.0 litres capacity, as required. Transferring the powder into other containers is no longer necessary. This considerably minimizes the potential release of unhealthy dusts. A fines sample is immediately ready for storage or can be passed right on to applications testing.



A wide range of applications

The laboratory R&D system 1050 can be used for testing and small-quantity production in almost any field.

Application examples: Fractionizing with air classifier Separano® 1050 E

high-quality powders for 3D print or surface coating: dust removal of metal powders (2 -15 µm) or of polymer powders such as PA, PP, POM PS, PE, TPU (10 - 20 µm).

- fractionizing of minerals, inorganic pigments and chemical products.
- protein shifting of vegetables, e.g. leguminosae.

Application examples with opposed jet mill MultiNo® 1050

- Inorganic and organic products such as pigments, oxides, waxes, activated carbon.
- Minerals such as zeolites, clay, mica, talcum.

Specifications

- Classifier revolutions: 3,000 to 24,000 1/min
- Classifying wheel materials: stainless steel, ceramic, Nollan (PA12 G)
- Fineness range: D97% = 2 - 60 µm
- Dimensions: 1720 x 750 x 1950 cm

[Bulksolids-portal](#)

The right cutting mill for every application!

Powerful comminution with variable rotational speed

The FRITSCH Universal Cutting Mills **PULVERISETTE 19** and **PULVERISETTE 19 large** ensure fast, easy comminution of a wide range of plastics/polymers as well as biological materials in small and large quantities. Its main areas of application include environment and recycling, secondary fuels/RDF in cement production, power generation and other similar contexts, as well as cannabis processing. There is a special stainless steel version for the foodstuffs and pharmaceutical sectors.

The gradually variable rotational speed setting allows optimal adjustment of the cutting speed to any sample material. The well-conceived structural design of the grinding chamber ensures optimized hygienic cleaning.

Overview of the main features:

- Variable rotational speed from 300 – 3000 rpm or 50 – 700 rpm for optimized torque
- Feed size up to 70x80 resp. 120x85 mm
- Throughput up to 60/85 l/h
- Variable final fineness with sieve cassettes from 0.1 – 20 mm
- Tool-free maintenance due to the three-part housing and plug-in rotor
- Suitable for GMP and RoHS
- Comminution without pre-crushing for long solids like cannabis, straw or foils



Universal Cutting Mill PULVERISETTE 19 large with funnel for bulk solids with sample pusher

Flexible modular principle

By simply changing the rotor, you can adapt your P-19 or P-19 large Cutting Mill perfectly to any sample material. We have a range of rotors and fixed knives with different cutting geometries in a variety of materials. By choosing the sieve cassettes, you can determine the final fineness of your samples. Different funnels, collecting vessels and stands made of a variety of materials enable further configuration exactly for your applications.

The connection to a FRITSCH high-performance or small volume Cyclone separator ensures simple feeding and cleaning, higher final fineness and faster throughput with minimized thermal load of the samples.

Convince yourself of the unmatched ease of cleaning:



The special features of the FRITSCH Cutting Mills and how they work can be seen in the video:



Experience the FRITSCH Cutting Mills virtually directly at your workplace and discuss your specific application with our application consultants. Just arrange your virtual consultation appointment now with our application consultant.

Make your appointment now!



Universal Cutting Mill
PULVERISETTE 19
with FRITSCH high-
performance Cyclone
separator and solid piping

Test the FRITSCH CUTTING MILLS!

Send us your most difficult sample – we will carry out an individual **sample grinding** for you. Compare for yourself!

Up-dated information on the whole FRITSCH Cutting Mill range at

www.fritsch-international.com/cutting-mills.

contact:

FRITSCH GmbH • Milling and Sizing

Selina Stemmler

Industriestrasse 8 • 55743 Idar-Oberstein • Germany

Phone +49 6784 70-155

E-Mail: sdstemmler@fritsch.de

Internet: www.fritsch.de

Ancora: advanced technology and assistance at the service of the ceramic end of line

Very high yield per square metre, extremely performing and competitive technologies, in a synergy between processing plants, machines and accessories for a complete ceramic end-of-line process tailored to the customer's needs. These are the characteristic features of Ancora, a company specialized in the ceramic end of line, part of Gruppo B&T.

The company has developed technologies and patents for each phase of this part of the process thanks to constant Research & Development and joint work with the most important international ceramic players.



The DrySquaring machine, Ancora's leading technology, is an advanced, extremely automatic and engineered system which, thanks to continuous technological upgrades, embraces the concepts of Smart Factory and Industry 4.0, demonstrating multiple advantages in terms of energy saving, eco-sustainability and reduction of production costs.



To these solutions Wet Polishing is added, a sanding and polishing line that can mount up to 24 heads with double oscillating bridges on a single module.

Ancora has also developed Flexy, an innovative variable geometry polishing head designed to improve the homogeneity of the glossy, reduce the consumption of tools and allow greater flexibility during polishing.

A very accessible patented system, based on a new arrangement of the tools in the head and intended to solve a common problem that today is handled manually by operators: the complexities linked to the flatness, convexity and concavity of large ceramic slabs.

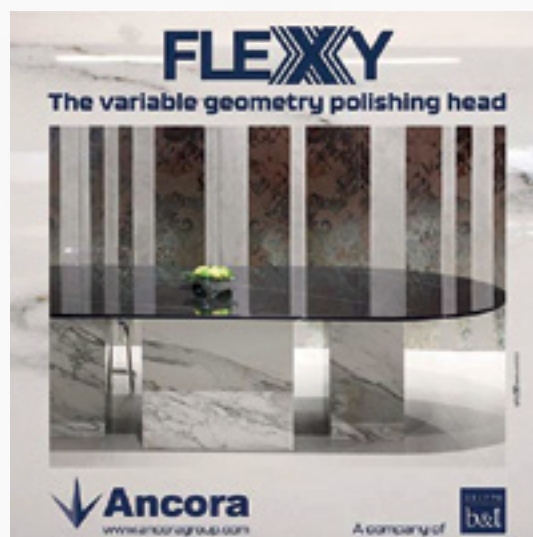

Ancora also has a pickling line, capable of preventing acid attacks, cleaning evenly by removing all stain traces and preventing the appearance of halos.

The highest interpretation of ceramic aesthetics is also Luxury, the high-glossy technology designed to enhance the graphics of the tile through a surface treatment that guarantees high gloss and protection.

Ancora also provides global maintenance services, supporting its customers through Ancora-TUTOR, the supervision software that allows monitoring, data collection, predictive maintenance and control of the entire plant.



Indian Global Magazine on Industry

INDUSTRIAL ANGLES

The Industrial Leader's Vision



**WANT TO BE HEARD?
WANT TO BE KNOWN?
WANT TO BE UNDERSTOOD?
WE CAN BE YOUR VOICE !!!**

Industrial Angles has 360 degree experience, expertise and exposure to reach to your Target audience and deliver your knack to them. Bank on us for all your communication needs!



**HO : F-49 Okhla, Phase-1, New Delhi-110020, INDIA
E. mail : industrial.angles@gmail.com
Cont. us : +91- 8827849864**

65th IEEE-IAS/PCA Cement Industry Technical Conference

 Dallas-Hilton Anatole, Dallas, USA

23→27
April
2023

[Website](#) 

Global Coal Outlook 2023 and beyond

 **Virtual event**
Registration is free

Thursday
27 April
2023

12 PM BST
(British Summer Time)

[Website](#) 

2nd Virtual Global CemCCUS - Carbon capture, use and storage for cement and lime

 Your device

10 May
2023

10:00 → 16:00 CET
Central European Time
Berlin, Paris, Rome

[Free registration](#) 

[Email](#) 

[Website](#) 

For more information, please contact:

Dr. Robert McCaffrey Tel.: +44 1372 743837 Fax: +44 1372 743838

Slag & AshTrade Europe 2023

 Lisbon, Portugal

10-11
May
2023

[Website](#) 

[Email](#) 

5th Global CemBoards Conference and Exhibition

 Hotel Pullman Brussels, Belgium

16-17
May
2023

[Website](#) 

[Cem-Boards](#) 

[Email](#) 

For more information, please contact:

Dr. Robert McCaffrey Tel.: +44 1372 743837 Fax: +44 1372 743838

Evolving the well-established

Training Programme 2023

Online Seminars

Cements of the Future
27 April 2023

**Firing Alternative Fuels: Opportunities,
Impacts on Process, Optimisation and
Limitations**
18 - 21 September 2023

In-class Training

**Crash Course for Young Engineers
and Scientists**
13 - 17 November 2023

E-Learning

**37 online courses on cement production.
Learn up-to-date content at your own
speed. Anytime. Anywhere.**

vdz



More information and registration:
www.vdz-online.de/en/training
training@vdz-online.de

Follow us on 

VDZ
Toulouser Allee 71
40476 Duesseldorf
Germany

Virtual (**free**) and
in-person events
in 2023 from:



Details and registration

Virtual Global CemCCUS 2

Carbon capture, use and storage for cement and lime
10 May 2023

**1st Global ConChems
Conference on Construction chemicals**
11-12 October 2023, Brussels, Belgium

5th Global CemBoards Conference
16-17 May 2023, Brussels, Belgium

**21st Global Gypsum/16th Global Insulation
Conference & Exhibition**
9-10 November, Chicago, USA

15th Global Slag Conference
**6-7 June 2023, Düsseldorf, Ger-
many**

Virtual MEAF Cement 4
Cement in Middle East/Africa
4 July 2023

Virtual Global Concrete 6
Global concrete business
12 September 2023

16th Global CemFuels Conference
20-21 September 2023, Sitanbul, Türkiye



Virtual Global CemProducer 7
Cement plant maintenance
21 November 2023

Virtual Global CemPower 3
Electrical generation and efficiency
28 November 2023

Virtual European Cement 3
Market trends and technology in Europe
5 December 2023

Virtual Global Ash 4
Ash for cement and concrete
12 December 2023

www.GlobalCement.com

Check website for
latest details



Diary dates

22nd Asia Cementrade Summit

 Bangkok, Thailand

For more information, please contact: Tel.: +65 6346 9146

23-24
May
2023

Website 

Email 

15th Global Slag Conference

 Düsseldorf, Germany

For more information, please contact:

Dr. Robert McCaffrey

Tel.: +44 1372 743837

Fax: +44 1372 743838

06-07
June
2023

Website 

Email 

7th American Drymix Mortar Conference - admmc7

 Richmond, Virginia, USA

08
June
2023

Website 

Email 

Second Interdisciplinary Symposium on 3D Printing of Mortars ScalingUp 3D

 Richmond, Virginia, USA

09
June
2023

Website 

Email 

INTERCEM ASIA 2023

 Parkroyal on Beach Road, Singapore

For more information, please contact Mrs Lola Carragher

12-14
June
2023

Website 

Email 

Virtual Global Mortars 1 Global mortars business

For more information, please contact:

Dr. Robert McCaffrey

Tel.: +44 1372 743837

Fax: +44 1372 743838

20
June
2023

10:00 → 16:00 CET
Central European Time
Berlin, Paris, Rome

Website 

Email 

Diary dates

Cemtech Asia 2023: Decarbonising the Asian Cement Sector

Manufacturing excellence and the circular economy

 **Meliá Hanoi, Vietnam**

For more information, please contact:

Dr. Robert McCaffrey

Tel.: +44 1372 743837

Fax: +44 1372 743838

**25-28
June
2023**

[Website](#) 

[Email](#) 

4th Virtual Middle Eastern and African Cement Conference

Market trends and technology in MEAF

 **Your device**

For more information, please contact:

Dr. Robert McCaffrey

Tel.: +44 1372 743837

Fax: +44 1372 743838

**4
July
2023**

[Free registration](#) 

[Email](#) 

[Website](#)
AfricanCement 

[Website](#)
MiddleEasternCement 

World Cement Network Conference

 **Hilton Bomonti Istanbul, Turkey**

For registration
please visit

**04-05
July
2023**

[Website](#) 

Or

[Email](#) 

The Green Cement Conference – Unlocking data driven net zero transition

 **Grand Hyatt Athens, Greece**

**10-12
July
2023**

[Website](#) 

[Website](#) 

WORLD CEMENT NETWORK CONFERENCE

**4-5 JULY 2023
HILTON BOMONTI ISTANBUL TURKEY**

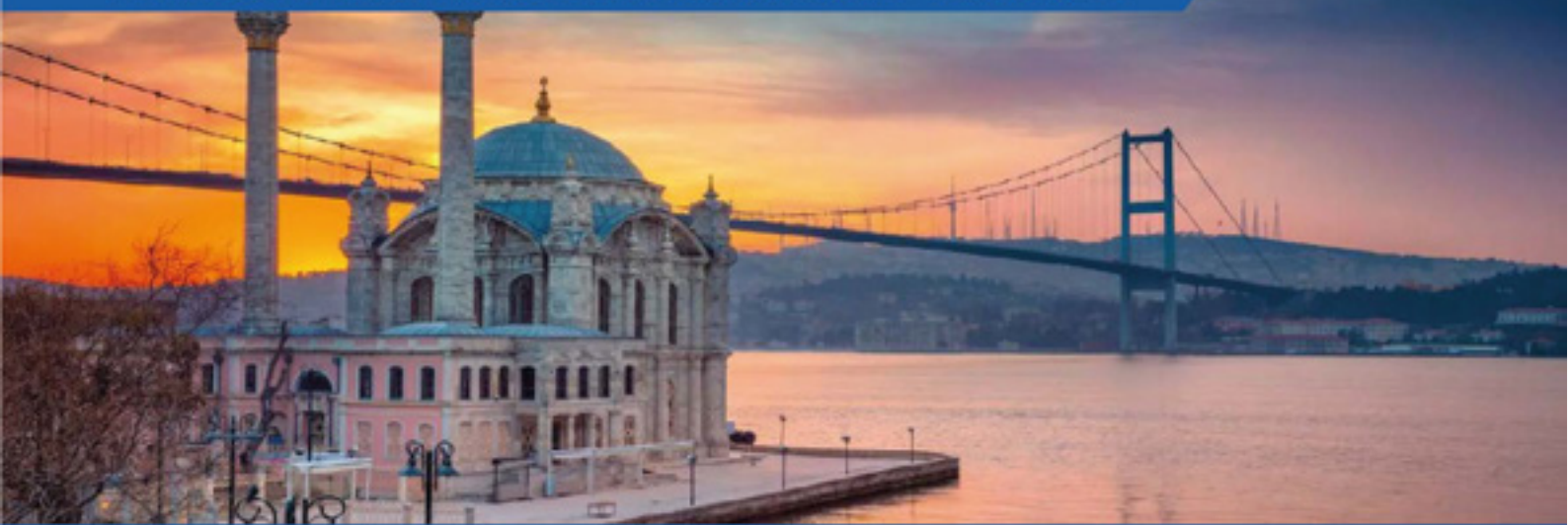

The World Cement Network Conference will take place from 4 to 5 July 2023, at Hilton Bomonti Hotel in Istanbul, Turkey.

The conference programme will include detailed presentations, round table discussions, power lunches, open contract negotiation bids for cement clinker, plenty of networking opportunities amongst industry colleagues from around the world and a magnificent Gala Dinner Event.

**GOLF TOURNAMENT
2-3 JULY**

**COMPREHENSIVE SPOUSES
PROGRAMME**

Subjects will include:

- International cement price and volume trends
- Global supply demand balance
- New technology in sustainable cement production
- Freight rate trends and forecast
- Coal and Petcoke market analysis
- Fly Ash and slag market assessment

FOR REGISTRATION CONTACT



admin@worldcementnetwork.ae



www.worldcementnetwork.ae

In association with



WORLD CEMENT NETWORK CONFERENCE IST 2023

The world's most important cement event occurs in Istanbul Turkey

Be updated about

- Global cement supply demand balance
- Major international cement market price trends
- Impact of CBAM on imports of cement into the EU
- New technologies in sustainable cement production
- Challenges facing the cement industry
- "Net zero" target of the global cement industry
- Cement markets in Europe, Asia, Africa
- Turkish cement export strategy
- US cement market forecast
- Coal and Petcoke market analysis
- Fly Ash and slag market assessment
- Freight rate trends and forecast

Learning about

- Making solid sale and purchase contracts
- International supervision and surveillance
- International trade law and jurisdiction
- Conflict resolution in International Clinker Contracts
- The benefits of International mediation by WCA
- Avoiding Anti-competitive behaviour in cement business
- The Making of the World Clinker FOB index
- How to make a low alkali cement clinker
- High potential international cement talent pool – WCN

NETWORKING with real cement people, connect with the best of the industry

For sponsorship please contact admin@worldcementnetwork.ae



www.worldcementnetwork.ae



In association with

WCA WORLD
CEMENT
ASSOCIATION



The 24th China International Cement Industry Exhibition

CEMENTTECH 2023



August 23-25, 2023



Chongqing International
Expo Center, China.



Organizer:



China Building Materials



China Cement Association



CCPIT Building Materials Sub Council

Contact Information:

Joanna Long

Tel: +86-10-88083329

Joannalong@ccpitbm.org;



WWW.CEMENTTECH.ORG

Diary dates

7th Latin American Drymix Mortar Conference and Industry Showcase Iadmmc7

 Espaço Escandinavo,
São Paulo, Brazil

7
August
2023

Website 

Email 

CEMENTTECH 2023 The 24th China International Cement Industry Exhibition

 Chongqing International Expo
Center, China

7
August
2023

Website 

Email 

For more information, please contact:

Ms. Joanna Long

Tel.: +86-10-88083329

6th Virtual Global Concrete - global concrete business

 Your device

For more information, please contact:

Dr. Robert McCaffrey

Tel.: +44 1372 743837

Fax: +44 1372 743838

10:00 → 16:00 CET
Central European Time

Berlin, Paris, Rome

12
September
2023

Registration 

Email 

Website 

16th Global CemFuels Conference & Exhibition Alternative Fuels for Cement and Lime

 Istanbul, Türkiye

For more information, please contact:

Dr. Robert McCaffrey

Tel.: +44 1372 743837

Fax: +44 1372 743838

20-21
September
2023

Email 

Website 

Diary dates

1st Global ConChems Conference & Exhibition on construction chemicals 2023

 **Brussels, Belgium**

For more information, please contact:

Dr. Robert McCaffrey

Tel.: +44 1372 743837

Fax: +44 1372 743838

**11-12
October
2023**

[Email](#) 

[Website](#) 

The 7th India Drymix Mortar Conference and Industry Showcase

 **Mumbai, India**

**17
October
2023**

[Email](#) 

[Website](#) 

XXV International Construction Forum | Cement Concrete - Dry Mixtures

 **Expocentre, Moscow, Russia**

For more information, please contact:

Tel.: +7 812 3350992

**18-20
October
2023**

[Email](#) 

[Website](#) 

CarbonZero Global Conference and Exhibition 2023

 **Lyon, France**

For more information, please contact:

Industry Link

Tel.: +40726 497 448

**26-27
October
2023**

[Email](#) 

[Email](#) 

[Website](#) 

21st Global Gypsum / 16th Global Insulation Conference & Exhibition

 **Chicago, USA**

For more information, please contact:

Dr. Robert McCaffrey

Tel.: +44 1372 743837

Fax: +44 1372 743838

**09-10
November
2023**

[Email](#) 

[Website](#) 



XXV INTERNATIONAL CONSTRUCTION FORUM

CEMENT - CONCRETE DRY MIXTURES

OCTOBER 18 - 20, 2023. EXPOCENTRE, MOSCOW.



XXV INTERNATIONAL CONSTRUCTION EXHIBITION
«Cement. Concrete. Dry mixtures»

More than **6000** exhibition visitors



International Conference
«Concrete Technologies:
Chemistry, Production, Precast»

450 members of the business program



International Scientific and Technical Conference
«Modern Technologies of Dry Mixtures in Construction»

150 exhibits

80 reports

18 countries

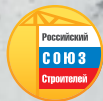

organizers

venue

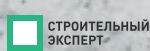
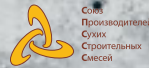

info@alitinform.ru // www.infocem.info // +7 812 335 09 92



International Cement Seminar & Exhibition 2023

 Cobb Galleria in Atlanta, USA

14-15
November
2023

Website 

7th Virtual Global CemProducer Seminar - cement production optimisation

 Your device

For more information, please contact:

Dr. Robert McCaffrey

Tel.: +44 1372 743837

Fax: +44 1372 743838

21
November
2023

Email 

The 16th Annual SEADMA Conference and Industry Showcase

 Indonesia

23
November
2023

Email 

Website 

3rd Virtual Global CemPower Seminar - Electrical generation and efficiency

 Your device

For more information, please contact:

Dr. Robert McCaffrey

Tel.: +44 1372 743837

Fax: +44 1372 743838

10:00 → 17:00 CET
Central European Time

Berlin, Paris, Rome

28
November
2023

Email 

Website 

Free registration 

Diary dates

5th Conference and 1st Exhibition of Cement Industry and Technology 2023

 **Damascus Fairground,
Damascus, Syria**

For more information, please contact:
Mobile/WhatsApp: +963969019984

3rd Virtual European Cement Conference - Market trends and technology in Europe

 **Your device**

For more information, please contact:

Dr. Robert McCaffrey

Tel.: +44 1372 743837

Fax: +44 1372 743838

4th Virtual Global Ash - Ash for cement and concrete

 **Your device**

For more information, please contact:

Dr. Robert McCaffrey

Tel.: +44 1372 743837

Fax: +44 1372 743838

4th Global FutureCem Conference & Exhibition - low CO₂ options for cement and concrete

 **TBC**

For more information, please contact:

Dr. Robert McCaffrey

Global FutureCem Conference convenor

Tel.: +44 1372 743837

Fax: +44 1372 743838

66th IEEE-IAS/PCA Cement Industry Technical Conference

 **Gaylord Rockies, Denver, USA**

30
November

↓

02
December

2023

[Email](#) 

[Website](#) 

10:00 → 17:00 CET
Central European Time

Berlin, Paris, Rome

05
December
2023

[Email](#) 

[Website](#) 

12
December
2023

[Email](#) 

[Website](#) 

2024

[Email](#) 

05-09
May
2024

[Website](#) 

Training

 Your device

Website 

Email 

Alternative Fuels for Firing Cement Kilns (3-Week Online Training)

03rd July 2023
02nd October 2023

Cement Kiln Process Chemistry (6-Week Online Training)

03rd July 2023
02nd October 2023

Cement Manufacturing Technology (6-Week Online Training)

03rd July 2023
02nd October 2023

Cement Kiln Refractories (6-Week Online Training)

10th July 2023

Cement Factory Maintenance (6-Week Online Training)

10th July 2023
09th October 2023

Decarbonizing Cement Manufacture (6-Week Online Training)

10th July 2023
09th October 2023

Cement Kiln Pyroprocessing (6-Week Online Training)

10th July 2023
09th October 2023

Grinding and Milling Systems (6-Week Online Training)

31st July 2023
09th October 2023

Cement Factory Quality Control (6-Week Online Training)

31st July 2023
30th October 2023

White Cement Manufacturing Technology (6-Week Online Training)

04th September 2023

Uniceramics Products Expo 2023

 Foshan, China

Tel: +86 18566021320

15-19
April
2023

Website 

Email 

Uniceramics Technology Expo 2023

 Foshan, China

Tel: +86 18566021320

30
May
2023 → 02
June
2023

Website 

Email 

Ceramics China 2023

 Canton Fair Complex,
Guangzhou, China

For more information, please contact
Unifair Exhibition Service Co., Ltd.

Tel: +86-20 8327 6389

19-22
June
2023

Website 

Email 

DEBURRINGEXPO 2023

 Messe Karlsruhe, Germany

For more information, please contact
Unifair Exhibition Service Co., Ltd.

Tel: +86-20 8327 6389

10-12
October
2023

Website 

ACHEMA 2024

 Frankfurt, Germany

For more information, please contact
Unifair Exhibition Service Co., Ltd.

Tel: +86-20 8327 6389

10-24
June
2024

Website 

Sustainable Mining Summit

 **Hotel Mayfair Lagoon,
Bhubaneswar (Odisha), India**

For more information, please contact:

Mr. Pramod Tyagi

Director General

Federation of Indian Mineral Industries

Tel.: +91-11-26814592/96

Fax: +91-11-26814594/93

**13-14
April
2023**

[Email](#) 

[Website](#) 

Global Aluminium Expo 2023

 **Virtual Online**
Time: 11 AM to 7 PM (GMT)

**18-20
April
2023**

[Registration](#) 

High-Rises & Vertical Construction Summit

 **Lindner Hotel & Residence
Main Plaza, Frankfurt, Germany**

For more information, please contact:

John Karras

Tel.: +603 2775 0067

**03-04
May
2023**

[Email](#) 

[Website](#) 

interpack Düsseldorf

 **Düsseldorf Trade Fair
Centre, Germany**

**04-10
May
2023**

[Website](#) 

Chief risk officer - designing a future of holistic resilience

 **Hotel Fort Canning, Singapore**

For more information, please contact:

John Karras

Tel.: +603 2775 0067

**10-11
May
2023**

[Email](#) 

[Website](#) 



Diary dates

13th ERBIL BUILD EXPO 13th Erbil International Building & Construction Municipality Equipment & Machinery Exhibition

Erbil International Fair Ground, Iraq

For more information, please contact:

International Sales & Marketing, tel.: +90 216 575 2828

23-26
May
2023

Email

Email

Website

5th International Underground Excavations Symposium UYAK2023 Istanbul Cities of the Future, Urban Tunnelling, and Underground Excavations

Hilton Istanbul Bosphorus
Convention Center, Istanbul, Turkey

Tel: +90 312 4251080

05-07
June
2023

Email

Website

SOLIDS Parma

Fiere di Parma, Italy

14-15
June
2023

Website

4th Annual BIM Summit

The Berkeley Hotel Pratunam,
Bangkok, Thailand

For more information, please contact:

Mr. John Karras

Tel.: +603 2775 0067

14-15
June
2023

Email

Website

11th Annual Modular, Prefab & Construction Tech

The Berkeley Hotel Pratunam,
Bangkok, Thailand

For more information, please contact:

Mr. John Karras

Tel.: +603 2775 0067

14-15
June
2023

Email

Website

Diary dates

2nd Sustainable Polyolefins, Markets & Innovations, HYBRID

 **Novotel Brussels City Centre, Brussels, Belgium**

For more information, please contact:
Ms. Grace Oh
Marketing Manager
Tel.: +65 63469147

**21-22
June
2023**

[Email](#) 

[Website](#) 

Maintenance and Reliability 4.0

 **Bangkok, Thailand**

For more information, please contact:
Mr. John Karras
Tel.: +603 2775 0067

**05-06
July
2023**

[Email](#) 

[Website](#) 

Advanced Manufacturing Summit

 **Singapore**

For more information, please contact:
Mr. John Karras
Tel.: +603 2775 0067

**16-17
August
2023**

[Email](#) 

[Website](#) 

Powtech 2023

 **Nürnberg, Germany**

For more information, please contact:
Mr. John Karras
Tel.: +603 2775 0067

**26-28
September
2023**

[Website](#) 

SOLIDS Rotterdam

 **Rotterdam, the Netherlands**

**04-05
October
2023**

[Website](#) 

 **Diary dates**
SYMAS® and MAINTENANCE Trade Fair 2023

14th International Trade Fair for Powder & Bulk Solids Technologies SYMAS®

14th International Trade Fair for Suppliers of Maintenance Products and Services MAINTENANCE

 **Expo Kraków, Poland**

For more information, please contact
Barbara Płuciennik
Project Manager / Team Leader
Tel.: +48 12 651 90 38 Fax: +48 506 038 382

18-19
October
2023

[Email](#) 

[Website](#) 

BUILD EXPO Egypt
4th Cairo International Building, Construction, Energy, Electricity Municipal Equipment Exhibition

 **Cairo International Conference Center, CICC, Egypt**

For more information, please contact:
International Sales & Marketing, tel.: +90 216 575 2828

26-28
October
2023

[Email](#) 

[Email](#) 

[Website](#) 

The 28th International Mining Congress and Exhibition of Türkiye (IMCET 2023)

 **Antalya, Türkiye**

Tel.: (+90 546) 4251072 Fax: (+90 312) 4175290

28
November
↓
01
December
2023

[Email](#) 

[Email](#) 

[Website](#) 

19th Edition SteelFab 2024
Machinery, Technology, Equipment

 **Sharjah, UAE**

For more information, please contact:

Adib:

[Email](#) 

Tel.: +971 55 5337314

Alroy:

[Email](#) 

Tel.: +971 50 3506541

08-11
January
2024

[Website](#) 

Subscribe today



A unique source
of information
for the latest
developments in
technology

Subscribe online at:
www.worldcement.com/subscribe

**WORLD
CEMENT®**



مجلة عالم الإسمنت ومواد البناء

تصدر عن الاتحاد العربي للإسمنت ومواد البناء

العدد 91

مارس / آذار 2023



26th Arab International Cement Conference & Exhibition (AICCE26)

Riyadh, Saudi Arabia
November 2023

المؤتمر والمعرض العربي الدولي السادس والعشرون
لصناعة الإسمنت ومواد البناء
الرياض، المملكة العربية السعودية
نوفمبر/ تشرين الثاني 2023

Arab Union for Cement & Building Materials (AUCBM)

Event Secretariat:

aicce26@aucbm.email

www.aucbm.net

المحتويات

نشاطات عربية



أخبار عربية



الموضوعات

المحافظة على دوران فرن الإسمنت

إعداد: زكي أوزيك، Ozek Makina Rotary Kiln Services - تركيا

الوصول إلى القيمة الشاملة

إعداد: Mark Mutter، JAMCEM Consulting – المملكة المتحدة

التوجهات المستقبلية في إدارة مصانع الإسمنت

إعداد: Sanwar M. Mishra – الهند

إعدادات محرك الحلقة الانزلاقية لتوصيل وتشغيل مطحنة

الإسمنت - اختيار فرشاة الكربون يحدث فرقاً كبيراً

إعداد: Sanwar M. Mishra – الهند

مؤتمرات ومعارض

رئيس التحرير - الأمين العام
المهندس أحمد محمود الروسان

مدير التحرير
سها منير كنعان

البريد الإلكتروني

aucbm@scs-net.org
aucbm1977@gmail.com

الموقع الإلكتروني

www.aucbm.net

ترحب هيئة تحرير المجلة بمساهمة السادة المهتمين والمتخصصين بهدف إثراء المادة التحريرية.

الآراء الموجودة بالمجلة لا تعبر بالضرورة عن رأي الاتحاد أو المجلة وإنما عن الرأي الخاص بكتابها ولا يتحمل الاتحاد أية مسؤولية قانونية تجاه ذلك.

3 مليون طن صادرات مجّع جيكا من الإسمنت

بلغت قيمة صادرات شركة إسمنت عين التوتة في باتنة التابعة للمجمع الصناعي لإسمنت الجزائر (جيكا) ما يقارب 12 مليون دولار في 2022 ، حيث بلغت الصادرات 360 ألف طن .

وصدّر مجّع جيكا ككل ، في نفس السنة ، 3 مليون طن من الإسمنت ، نحو دول غرب إفريقيا وأمريكا اللاتينية وأوروبا ، بقيمة 106 ملايين دولار . ويهدف المجمع ، عبر فرعه في عين التوتة وعلى غرار كافة فروعها الصناعية، إلى الرفع من كمية الإسمنت المصدّرة تماشياً مع سياسة السلطات العمومية الرامية إلى تنويع الصادرات خارج قطاع المحروقات.

www.aajilnews.dz

مصنع الإسمنت بالشلف يصدر حوالي 350 ألف طن من الكلنكر منذ بداية العام

قام مصنع الإسمنت للشلف التابع للمجمع الصناعي لإسمنت الجزائر "جيكا" منذ بداية العام الجاري بتصدير حوالي 350 ألف طن من مادة الكلنكر، وذلك نحو بلدان من أوروبا وإفريقيا وأمريكا اللاتينية انطلاقاً من مينائي تنس (الشلف) ووهران.

ويطمح مصنع الإسمنت للشلف هذه السنة إلى تصدير 2 مليون طن من الكلنكر إلى عدد من الدول الأوروبية والإفريقية وأمريكا اللاتينية . وقد تم خلال العام الماضي تصدير 1 مليون و500 ألف طن حيث أن السوق الوطنية "مشبعة بمادة الإسمنت" .

من جهة أخرى ، يطمح المصنع خلال العام الجاري إلى تصدير 1 مليون طن من الإسمنت نحو الدول الأوروبية والإفريقية ، مع استعداد الشركة إلى تصدير الإسمنت إلى تركيا وسوريا بعد الزلزال العنيف الذي ضرب البلدين مؤخراً .

ويحتوي مصنع الإسمنت بالشلف التابع للمجمع الصناعي لإسمنت الجزائر "جيكا" على ثلاثة خطوط لإنتاج الإسمنت بطاقة إجمالية تقدر بـ 4 ملايين و200 ألف طن سنوياً من الإسمنت بالإضافة إلى مادة الكلنكر .

الجزائر

لافارج الجزائر توقع اتفاقية شراكة للتنمية المستدامة

وقع المركز الوطني لتقنيات الإنتاج الأنظف (CNTPP) وشركة لافارج الجزائر في ديسمبر / كانون الأول 2022 اتفاقية تعاون علمي وتقني في نهج التنمية المستدامة .

ويهدف هذا التعاون الأول من نوعه في هذا المجال بالجزائر إلى دعم المنشآت الصناعية لشركة لافارج في الجزائر عضو مجمع هولسيم، من خلال CNTPP في جهودها التطوعية للحد من البصمة البيئية .

تتوج هذه المبادرة الخطوات التي اتخذتها لافارج الجزائر لعدة سنوات لتكييف استراتيجية النمو الأخضر لمجمع "هولسيم" في الجزائر :

إطلاق الإسمنت شامل إكوبلانات في سبتمبر / أيلول الماضي ، وهو أول إسمنت «أخضر» في الجزائر ، والذي يقدم أداءً متساوياً وبصمة كربونية مخفضة بنسبة 40% مقارنة بالإسمنت التقليدي، وذلك بفضل العمليات الصناعية المبتكرة والحفاظ على الموارد المحلية . استبدال الطين بالسد الطمي والحديد مع الحمأة الحديدية المتبقية ، كما يشمل الحفاظ على الموارد الطبيعية الأحفوري وغير المتجددة عن طريق البدائل ، التي تأتي من النفايات و/أو المخلفات الصناعية . وكذلك للاستجابة لقضية حماية البيئة من خلال المعالجة المحلية للنفايات الخطرة الخاصة والخاصة ، إلى جانب تجديد أسطول جديد بشاحنات أحدث أقل تلويثاً ، وكذا إطلاق دراسات لتطوير الطاقة الشمسية في مواقع الشركة .

www.elmasdaronline.dz

المملكة العربية السعودية

إسمنت المنطقة الشرقية تعلن عن إنشاء خط جديد
بطاقة إنتاجية 10,000 طن/يوم

إسمنت الجنوب تقرر البدء في إنشاء خط بطاقة
إنتاجية تبلغ 5000 طن يومياً

أعلنت شركة إسمنت المنطقة الشرقية عن مشروع إنشاء خط إنتاج جديد في مصنع الشركة بطاقة إنتاجية (10,000 طن/يوم)، ليتم إحلاله محل بعض خطوط الإنتاج الحالية .

وأوضحت الشركة أن لديها رخصة استغلال الحجر الجيري بمنطقة الخرسانية ، بالإضافة إلى رخصة استغلال الحجر الجيري بمنطقة النجيبية . وأضافت أن مجلس الإدارة قرر توجيه الدعوة للشركات المتخصصة لتقديم العروض الخاصة بإنشاء خط الإنتاج الجديد بطاقة (10,000 طن/يوم) بغرض إحلاله محل بعض خطوط الإنتاج المتقادمة في مصنع الشركة الحالي بمنطقة الخرسانية ، وذلك لتعظيم الاستفادة من البنية التحتية للمصنع الحالي.

قرر مجلس إدارة شركة إسمنت المنطقة الجنوبية "إسمنت الجنوب" البدء في إنشاء خط بطاقة إنتاجية 5000 طن يومياً ، مع إنشاء البنية التحتية لخط آخر بطاقة إنتاجية تبلغ أيضاً 5000 طن يومياً .

وذكرت الشركة أن ذلك يأتي بعد استكمال الدراسات الفنية التفصيلية بالاستعانة بمكتب استشاري متخصص ، على أن يتم الإعلان عن أي تطورات جوهرية لاحقاً . وكانت إسمنت الجنوب قد قررت في يونيو / حزيران الماضي إنشاء خط إنتاج في مصنع جازان بطاقة إنتاجية 10 آلاف طن في اليوم ليتم إحلاله محل خطوط الإنتاج الحالية .

www.alarabiya.net

شركة إسمنت اليمامة تعلن توقيع عقد نقل الخط
السابع من المصنع القديم إلى المصنع الجديد

وقعت شركة إسمنت اليمامة في نوفمبر / تشرين الثاني 2022 عقداً لفك ونقل وتركيب الخط السابع مع شركة Sinoma Overseas الصينية من المصنع القديم في جنوب مدينة الرياض إلى موقع المصنع الجديد في الحلال الشمالية بمحافظة الخرج التابعة لمنطقة الرياض ، حيث تبلغ طاقة الخط الإنتاجية 10 آلاف طن/كلنكر يومياً ، بتكلفة تقديرية 830 مليون ريال سعودي .

والتاريخ المتوقع للبدء في المشروع هو الربع الأول 2023 والتاريخ المتوقع لانتهاء من المشروع هو النصف الثاني من عام 2025 ، وبذلك ستكون الطاقة الإنتاجية في الموقع الجديد 30 ألف طن كلنكر يومياً .

www.okaz.com.sa



SIMAN NEWS

Iran Cement News Agency



www.simankhabar.ir

پایگاه خبری تحلیلی صنعت سیمان ایران



simankhabar



@simankhabar

IRAN Cement Industry Capabilities and Equipments Production in SimanKhabar.ir

SK Automatic Big Bag Filling Station With Lifting System



For Export



SK Cement Packing Plant



For more information please contact us :



Tel : +98 21 6642 89 14

Fax: +98 21 6691 53 29

info@simankhabar.ir



العراق

الشركة العامة للسمنت العراقية تدخل في شراكة مع شركة تركية لإنشاء معمل جديد بطاقة عقدية تقارب المليون طن سنوياً

مضيفاً إلى ذلك أن إنشاء المعمل الذي سيكون على النفقة الخاصة للشركة المُستثمرة ، وكما نصَّ العقد على إنشاء محطة كهربائية ، وفي حال اقتضت الحاجة إلى شراء أرض لغرض توسيع المعمل ، فمجمّل تلك الفقرات ستكون عائدتها إلى السمنت العراقية.

ذاكراً أن الشركة المُستثمرة ستعمل على منح 10% من الطاقة العقدية كحصّة مجانية للشركة، التي تمثّل حوالي 50% من صافي الربح ، كما ستلتزم بدفع رواتب العاملين الذين هم في الأساس ضمن الكوادر العاملة في معاونة السمنت الشمالية ، فضلاً عن العمل على تنفيذ برنامج مشترك لتطوير خبرات الكوادر الفنية والهندسية عن طريق إدخالهم بدورات تدريبية مختصة بالإنشاء وطرق التشغيل الحديثة .

من المتوقع أن تعود هذه الشراكة بمنافع اقتصادية كبيرة لكلا الشركتين ، التي ستدفع بعجلة الاقتصاد نحو التقدم ، إلى جانب تعضيد صناعة السمنت عبر إضافة معامل جديدة تعمل بالتكنولوجيا الحديثة ، ومواكبة للشروط والمحددات والمعايير المحلية والدولية .

أعلنت الشركة العامة للسمنت العراقية ، إحدى شركات وزارة الصناعة والمعادن الرائدة في صناعة السمنت ، عن توصلها لإبرام عقد استثماري وفق آلية المشاركة بالإنتاج مع شريك تركي المتمثل بشركة (زودياك للإنشاءات والتجارة العامة) ، وذلك لإنشاء معمل جديد ضمن مجمع حمام العليل في محافظة نينوى .

وقال مدير عام الشركة المهندس حسين محسن عبيد أن الشركتين ستعملان معاً على بناء شراكة حقيقية تفضي إلى إرساء بنود العقد في محل الفعل لإنشاء هذا المعمل لكي تتحقق أهداف الطرفين ، في تعزيز وتحديث صناعة السمنت ، وتماشياً مع الرؤية الوزارية القاضية لضرورة تشغيل المعامل المتوقفة أو العمل على إنشاء خطوط إنتاجية جديدة تؤدي إلى سد حاجة البلد من هذه المادة الحاكمة لمشاريع البناء والإعمار .

مؤكداً ، إنّه بموجب بنود عقد المشاركة ، ستعمل شركة (زودياك التركية) على إنشاء معمل جديد يعمل بتكنولوجيا حديثة ، وبوقود الغاز الجاف لإنتاج السمنت بمختلف أنواعه ، وبطاقة عقدية تصل إلى مليون وثمانمائة ألف طن سنوياً ، مقابل أن الشركة العامة للسمنت ستعمل على توفير قطعة الأرض اللازمة لذلك .

سلطنة عُمان

شركات استراتيجية بين شركات ضخمة لتنويع مصادر الدخل في الدقم

ويعمل الكيان الجديد تحت مسمى "شركة الدقم الدولية للمشاريع الإسمنتية" بالتنسيق مع مسؤولي إدارة المنطقة الاقتصادية الخاصة بالدقم التابعة لإدارة الهيئة العامة للمناطق الاقتصادية الخاصة والمناطق الحرة لتسريع الإجراءات والحصول على الموافقات والتصاريح اللازمة وتوفير البيئة الاستثمارية لها في المنطقة الاقتصادية الخاصة بالدقم .

عقدت بالمنطقة الاقتصادية الخاصة بالدقم شراكة استراتيجية بين شركة ألترا تيك للإسمنت الهندية المحدودة Ultra Tech ، وهي الشركة الرئيسية لمجموعة أديتيا بيرلا ، وبين شركة "البحار السبع" ، للاستثمار في شركة الدقم الدولية للمشاريع الإسمنتية (DCPI) التي كانت مملوكة بالكامل لشركة "البحار السبع" .

وتبلغ الطاقة الإنتاجية لشركة ألترا تي ك في الهند حالياً 121 مليون طن سنوياً والتي من المتوقع أن يصل إنتاجها إلى 159 مليون طن بحلول نهاية السنة المالية 2025 . وتوجد لدى الشركة في منطقة الخليج العربي مرافق تصنيع في دولة الإمارات العربية المتحدة ودولة البحرين .

www.omandaily.om

الجدير بالذكر أن مجموعة أديتيا بيرلا (ABG) هي تكتل استثماري متعدد الجنسيات مع وجود فروع للمجموعة في 36 دولة حول العالم . في حين تلعب المجموعة في الهند أدواراً قيادية في قطاعات مختلفة مثل الإسمنت الرمادي والصدود الكاوية والكيماويات المتخصصة والنحاس وألياف الفسكوز . وعلى الصعيد العالمي تعتبر مجموعة أديتيا بيرلا (ABG) الشركة الرائدة في درفلة الألمنيوم وتحتل المرتبة الثانية في صناعة ألياف الفسكوز الأساسية وأسود الكربون .

جمهورية مصر العربية

وتمت مراسم التوقيع بمقر مصنع النهضة بمحافظة قنا . ويعد هذا التعاقد تجديداً لثقة شركة إسمنت النهضة في القدرات الفنية والإدارية لشركة أسيك التي تقوم بإدارة المصنع منذ عام 2011 .

وقد عبر الطرفان عن سعادتهما بهذا الاتفاق وتعهدا بمواصلة التعاون المثمر في الفترة القادمة وتطلعهما إلى مرحلة جديدة من التعاون لتحقيق النجاح والتقدم والازدهار للشركتين .

وتستهدف الشركة ضخ استثمارات سنوية بهدف التوسع باستراتيجيتها لتقليل الانبعاثات الكربونية وخفض محتوى الكلنكر بمنتجاتها لنحو 70% بحلول عام 2025 . وتسعى الشركة أيضاً للتوسع باستخدام الوقود البديل ضمن مزيج الطاقة لديها بما يتسق مع رؤيتها إلى الوصول بنسبة الانبعاثات الكربونية لمستوى صفر بحلول عام 2050 ، وتتطلع الشركة لمواصلة التوسع في استخدام مصادر الطاقة البديلة ضمن مزيج الطاقة لتصل إلى 50% خلال الأعوام الثلاثة المقبلة في مقابل 22% خلال الفترة الراهنة .

وتنفذ الشركة خططها نحو تنمية الاقتصاد الأخضر بما يتماشى مع الأهداف المناخية الأكثر طموحاً لعام 2030 ، كما تتطلع الشركة لتبادل خبراتها العالمية في صناعة أفضل أنواع الإسمنت الذي يطابق معايير الحفاظ على البيئة .

تجديد تعاقد الإدارة الفنية مع شركة النهضة للصناعات

احتفلت الشركة العربية السويسرية للهندسة (أسيك) في فبراير / شباط 2023 بتوقيع تجديد تعاقد الإدارة الفنية مع شركة النهضة للصناعات (إسمنت النهضة) حيث يستمر التعاون بين الشركتين لمدة ثلاثة أعوام حتى نهاية مارس / آذار 2026 .

لافارج مصر تستهدف إنتاج إسمنت صديق للبيئة وتقليل الانبعاثات الكربونية لمصانعها

تستهدف شركة لافارج مصر - إحدى شركات مجموعة هولسيم العالمية - إنتاج إسمنت صديق للبيئة في إطار دعم الدولة للتحول للاقتصاد للأخضر ، وقد بدأت اتخاذ خطوات إيجابية لتقليل الانبعاثات الكربونية والوصول إلى عالم خالي من الانبعاثات الكربونية بحلول 2050 .

والفكرة هي تقليل الانبعاثات عن طريق تجميع الكربون الناتج عن التشغيل وتحويله إلى وقود ، والهدف هو تقليل الانبعاثات الكربونية من العالم ويحتاج ذلك إلى تنظيم من الحكومة عن طريق وضع أسعار على الانبعاثات الكربونية ومتابعتها .

وطرحت الشركة منتجات جديدة تقوم بشكل أساسي على البناء الأخضر وتقليل البصمة الكربونية البيئية، مثل منتجات "ECOPlanet" و "ECOPlanet Prime" والتي تقلل الانبعاثات الكربونية ما بين 50 إلى 60%، وأخيراً منتج شطبنا ذات البصمة الكربونية 40% فقط والذي تم طرحه خلال شهر يونيو / حزيران الماضي ليقدم قطاع أعمال التشطيبات .

moc.swenaasrobla.www

الأحمر. ومن المقرر أن تكون المحطة البحرية جاهزة للعمل في الربع الثاني من عام 2025 .

وفي إطار اتفاقية الامتياز ، ستخصص مجموعة موانئ أبوظبي استثمارات إجمالية تصل إلى 200 مليون دولار أمريكي لتطوير البنى الفوقية وتجهيز المعدات ، والأبنية والمرافق العقارية الأخرى ، وشبكة الخدمات العامة داخل منطقة الامتياز .

وتم توقيع الاتفاقيتين لمدة 15 عاماً بين مجموعة موانئ أبوظبي والهيئة العامة لتنمية المنطقة الاقتصادية لقناة السويس ، حيث ستقوم المجموعة بموجبها بإنشاء محطتين في ميناء العريش وميناء غرب بورسعيد لمناولة الإسمنت السائب .

كما ستقوم المجموعة بإنشاء صوامع بسعة تخزينية تصل إلى 60 ألف طن في ميناء العريش، و30 ألف طن في ميناء شرق بورسعيد، وستكون كل محطة قادرة على مناولة ما يتراوح بين مليون إلى مليون ونصف طن سنوياً ، ما يسهم في مضاعفة صادرات مصر من الإسمنت إلى الأسواق العالمية. ومن المتوقع البدء بتشغيل المحطتين في الربع الرابع من 2023 .

مجموعة موانئ أبوظبي تبرم اتفاقية امتياز لمدة 03 عاماً لتطوير وتشغيل ميناء سفاجا المصري

أعلنت مجموعة موانئ أبوظبي عن توقيع اتفاقية امتياز لتطوير وتشغيل ميناء سفاجا المصري باستثمارات تبلغ 200 مليون دولار، بالإضافة إلى اتفاقيتين لمدة 15 عاماً لإنشاء محطتين لمناولة الإسمنت ومذكرة تفاهم وثلاث اتفاقيات مبدئية تشمل موانئ مصرية تطل على البحرين الأحمر والمتوسط ، ما يساهم في توسيع أنشطة المجموعة بشكل كبير في مصر .

وتهدف هذه الاتفاقيات إلى توفير موانئ متعددة الأغراض ، ومحطات السفن السياحية ، وتعزيز القدرات اللوجستية في مدن سفاجا والعين السخنة وبورسعيد والغردقة وشرم الشيخ والعريش .

ووقعت مجموعة موانئ أبوظبي والهيئة العامة لموانئ البحر الأحمر اتفاقية امتياز لمدة 30 عاماً، تمنح المجموعة حق تطوير وتشغيل محطة متعددة الأغراض في ميناء سفاجا المصري ، والذي يتمتع بموقع استراتيجي يطل على ساحل البحر

المملكة المغربية

مصنع إسمنت miCavon في المغرب ينتج أول إسمنت له

OK ، والتي تم تركيبها لأول مرة في البلاد . وكانت FLSmidth قد صرحت في عام 2019 أنها بصدد بناء مصنع لـ TEKCIM بالتعاون مع الشركة العامة للأشغال المغربية (SGTM) على أن يبدأ التشغيل الكامل في عام 2023 .

أنتج مصنع الإسمنت الجديد NovaCim البالغة طاقته الإنتاجية 1.4 مليون طن سنوياً في أولاد غانم بالقرب من الجديدة أول إسمنت له . وقامت شركة FLSmidth الدنماركية بتوريد المعدات ، بما في ذلك طاحونة أسطوانية عمودية من النوع



WWW.**UAECement.com**

Become a member of UAECEMENT.COM ...

ARAB CEMENT FACTORIES

UAE CEMENT NEWS

UAE CEMENT FACTORIES

RELIABLE COMPANIES

INTERNATIONAL CEMENT CONFERENCES

CEMENT ARTICLES

UAE CEMENT TYPES

Our Partners :



www.aucbm.net

SIMAN NEWS

Iran Cement News Agency

www.simankhabar.ir

www.simankhabar.ir



www.cmtevents.com

UAE CEMENT PORTAL WEB SITE

www.UAECEMENT.com

info@uaecement.com

شراكة جديدة لتسريع خفض البصمة الكربونية لصناعة الإسمنت باستخدام تقنية الذكاء الاصطناعي

شركة Carbon Re مقرها إنجلترا و شركة A³&Co. مقرها دولة الإمارات العربية المتحدة توحدان جهودهما لمساعدة الشركات المصنعة على خفض التكاليف والانبعاثات الكربونية في آن واحد.

وستمكن هذه الشراكة الاستراتيجية مع A³&Co. المزيد من منتجي الأسمنت من الاستفادة من فرص توفير النفقات التشغيلية التي توفرها خاصية الذكاء الاصطناعي في الوقت الذي تواجه فيه الصناعة التحديات المتمثلة في خفض انبعاثات الكربون وارتفاع أسعار الوقود.

حيث يتخصص فريق A³&Co. بالاستشارات الاستراتيجية وإدارة المشاريع في صناعة الإسمنت، والتي تتضمن إستشارات الحلول الرقمية الفريدة من نوعها في صناعة الإسمنت عالمياً، والتي تهدف لدعم جميع القطاعات التي تتعلق بالإنشاءات بشكل عام و صناعة الإسمنت بشكل خاص لمواجهة تحدي تقليل الانبعاثات الكربونية من خلال خارطة طريق تعتمد حلول عملية و نتائج محسوبة مسبقاً لضمان الحفاظ على الميزة التنافسية لمصنعي الإسمنت والوصول إلى لمستقبل البناء الأخضر.

وأكد المهندس عمرو نادر الرئيس التنفيذي والشريك المؤسس لشركة A³&Co. بدوره "إن هذه الشراكة الإستراتيجية تعتبر من أهم إتفاقيات التعاون التي أجريناها بما يتعلق بخفض البصمة الكربونية والوصول للصفر الكربوني في الصناعة، حيث أن هناك الكثير من الحديث عن أزمة المناخ ولكن ليس هناك ما يكفي من الخطوات الحقيقية لتقليل الانبعاثات بشكل فعلي. سوف توفر هذه الشراكة فوائد ملموسة مع نتائج قابلة للقياس على مستوى الصناعة والمناخ في آن واحد."

6 فبراير 2023، نحو خفض البصمة الكربونية من صناعة الإسمنت تم توقيع شراكة استراتيجية بين شركة Carbon Re، الشركة الرائدة في مجال تكنولوجيا المناخ، مع شركة A³&Co. المتخصصة في استشارات تصنيع الإسمنت، حيث تتضمن هذه الشراكة مساعدة مصنعي الأسمنت على تحسين عمليات الإنتاج لتقليل التكاليف التشغيلية وانبعاثات الكربون إلى مستويات لا يمكن تحقيقها بالطرق التقليدية، وذلك من خلال تقنية Delta Zero والتي تساهم بخفض استخدام الوقود بنسبة تصل إلى 10% إضافة لخفض الانبعاثات الكربونية بنسبة تصل إلى 20%، وذلك بناء على التجارب التي أجريت في عدة مصانع إسمنت حول العالم عبر ثلاث قارات، والتي من الممكن أن تصل في مصنع الأسمنت المتوسط الانتاجية إلى قرابة 50 كيلو طن من الانبعاثات الكربونية سنوياً.

حيث تستخدم هذه التقنية خاصية الذكاء الاصطناعي لوضع نموذج للإنتاج الأمثل لمصنع الأسمنت من خلال التحسين الأقصى للعمليات وأقل إستخدام للوقود و بأقل انبعاثات كربونية ممكنة بدون أي نفقات رأسمالية.

علق الرئيس التنفيذي والشريك المؤسس لشركة Carbon Re المهندس شريف السيد "إن تقنية Delta Zero تتميز بتأثيرها الكبير على بعض الصناعات الأكثر استخداماً للطاقة في العالم،



موقع إنترنت



موقع إنترنت



بريد إلكتروني



11-09
مايو/ أيار
2023

المعرض الدولي للكهرباء والطاقة والآلات والمعدات
واللوازم الصناعية SEMEX'23 2023

عمّان ، المملكة الأردنية الهاشمية

Muna Alkam

الجهة المنظمة: Global Exhibition Est.

Global Exhibition Est.

Phone : +962 65690066, +962 65690067

Mobile : +962 795926237

موقع إنترنت



بريد إلكتروني



30
نوفمبر / تشرين الثاني
2023
↓
02
ديسمبر / كانون الأول
2023

المؤتمر الخامس لتكنولوجيا صناعة الإسمنت
المعرض الأول لتكنولوجيا صناعة الإسمنت

مدينة المعارض - دمشق ، الجمهورية العربية السورية

الجهة المنظمة: مجموعة "سيم تك"

جوال - واتس اب: +963969019984

هاتف: +963114476769

دورات تدريبية عربية

بريد إلكتروني



11-07
مايو/ أيار
2023

التطوير المؤسسي لتحقيق أهداف التنمية المستدامة

القاهرة، جمهورية مصر العربية / اسطنبول، تركيا

الجهة المنظمة: المؤسسة العامة للتدريب المهني

للحصول على كافة التفاصيل يرجى التواصل مع إدارة التدريب:

هاتف : +20235822984

جوال / واتساب / فايبر: +201007570041

بريد إلكتروني



11-07
مايو/ أيار
2023

تنمية مهارات مديري مكاتب الإدارة العليا

القاهرة، جمهورية مصر العربية / اسطنبول، تركيا

الجهة المنظمة: المؤسسة العامة للتدريب المهني

للحصول على كافة التفاصيل يرجى التواصل مع إدارة التدريب:

هاتف : +20235822984

جوال / واتساب / فايبر: +201007570041



إعداد خطط الجودة للمشروعات والعقود

القاهرة، جمهورية مصر العربية / اسطنبول، تركيا
 الجهة المنظمة: المؤسسة العامة للتدريب المهني
 للحصول على كافة التفاصيل يرجى التواصل مع إدارة التدريب:
 هاتف : +20235822984
 جوال / واتساب / فايبر: +201007570041

11-07
 مايو/ أيار
 2023

بريد إلكتروني



أسس وآليات الاستقطاب والاختيار والتعيين

القاهرة، جمهورية مصر العربية / اسطنبول، تركيا
 الجهة المنظمة: المؤسسة العامة للتدريب المهني
 للحصول على كافة التفاصيل يرجى التواصل مع إدارة التدريب:
 هاتف : +20235822984
 جوال / واتساب / فايبر: +201007570041

11-07
 مايو/ أيار
 2023

بريد إلكتروني



المهارات المتكاملة في إدارة المستودعات ومراقبة المخزون

القاهرة، جمهورية مصر العربية / اسطنبول، تركيا
 الجهة المنظمة: المؤسسة العامة للتدريب المهني
 للحصول على كافة التفاصيل يرجى التواصل مع إدارة التدريب:
 هاتف : +20235822984
 جوال / واتساب / فايبر: +201007570041

11-07
 مايو/ أيار
 2023

بريد إلكتروني



التحليل الإحصائي للبيانات الضخمة

القاهرة، جمهورية مصر العربية / اسطنبول، تركيا
 الجهة المنظمة: المؤسسة العامة للتدريب المهني
 للحصول على كافة التفاصيل يرجى التواصل مع إدارة التدريب:
 هاتف : +20235822984
 جوال / واتساب / فايبر: +201007570041

11-07
 مايو/ أيار
 2023

بريد إلكتروني



المراجعة المالية والإدارية لضمان سلامة الأداء المالي

القاهرة، جمهورية مصر العربية / اسطنبول، تركيا
 الجهة المنظمة: المؤسسة العامة للتدريب المهني
 للحصول على كافة التفاصيل يرجى التواصل مع إدارة التدريب:
 هاتف : +20235822984
 جوال / واتساب / فايبر: +201007570041

11-07
 مايو/ أيار
 2023

بريد إلكتروني





صياغة النظم واللوائح القانونية والقرارات الإدارية

القاهرة، جمهورية مصر العربية / اسطنبول، تركيا

الجهة المنظمة: المؤسسة العامة للتدريب المهني

للحصول على كافة التفاصيل يرجى التواصل مع إدارة التدريب:

هاتف : +20235822984

جوال / واتساب / فايبر: +201007570041

11-07
مايو/ أيار
2023

بريد إلكتروني



الجوانب التقنية في نظم دعم اتخاذ القرارات الذكية

القاهرة، جمهورية مصر العربية / اسطنبول، تركيا

الجهة المنظمة: المؤسسة العامة للتدريب المهني

للحصول على كافة التفاصيل يرجى التواصل مع إدارة التدريب:

هاتف : +20235822984

جوال / واتساب / فايبر: +201007570041

11-07
مايو/ أيار
2023

بريد إلكتروني



المنتدى العربي الثالث - ريادة الأعمال، آفاق وتحديات استراتيجية التنمية المستدامة

القاهرة، جمهورية مصر العربية

الجهة المنظمة: الدار العربية للتنمية الإدارية

للحصول على كافة التفاصيل يرجى التواصل مع: مدير التدريب:
أ. سارة عبد الجواد

واتساب +201062992510 / +201096841626

هاتف +20237800583 / +20237800693

فاكس +20237800573 / +20235866323

17-14
مايو/ أيار
2023

موقع إنترنت



بريد إلكتروني



الإدارة الاستراتيجية للموارد البشرية

القاهرة، جمهورية مصر العربية / اسطنبول، تركيا

الجهة المنظمة: المؤسسة العامة للتدريب المهني

للحصول على كافة التفاصيل يرجى التواصل مع إدارة التدريب:

هاتف : +20235822984

جوال / واتساب / فايبر: +201007570041

18-14
مايو/ أيار
2023

بريد إلكتروني





تنمية مهارات العاملين على أعمال السكرتارية وإدارة المكاتب الذكية

القاهرة، جمهورية مصر العربية / اسطنبول، تركيا

الجهة المنظمة: المؤسسة العامة للتدريب المهني

للحصول على كافة التفاصيل يرجى التواصل مع إدارة التدريب:

هاتف : +20235822984

جوال / واتساب / فايبر: +201007570041

بريد إلكتروني



18-14
مايو/ أيار
2023

أهم المستجدات في معايير التقارير المالية الدولية (IFRS) ومعايير الاستدامة

القاهرة، جمهورية مصر العربية / اسطنبول، تركيا

الجهة المنظمة: المؤسسة العامة للتدريب المهني

للحصول على كافة التفاصيل يرجى التواصل مع إدارة التدريب:

هاتف : +20235822984

جوال / واتساب / فايبر: +201007570041

بريد إلكتروني



18-14
مايو/ أيار
2023

بناء الصف الثاني من القيادات: مراحل تمكين القادة

القاهرة، جمهورية مصر العربية / اسطنبول، تركيا

الجهة المنظمة: المؤسسة العامة للتدريب المهني

للحصول على كافة التفاصيل يرجى التواصل مع إدارة التدريب:

هاتف : +20235822984

جوال / واتساب / فايبر: +201007570041

بريد إلكتروني



18-14
مايو/ أيار
2023

أخصائي تطوير الاعمال المعتمد

القاهرة ، جمهورية مصر العربية

الجهة المنظمة: الدار العربية للتنمية الإدارية

للحصول على كافة التفاصيل يرجى التواصل مع: مدير التدريب:

أ. سارة عبد الجواد

واتساب :

+201062992510 / +201096841626

موقع إنترنت



بريد إلكتروني



18-14
مايو/ أيار
2023



مجلة عالم الإسمنت ومواد البناء

جدول موضوعات المجلة 2023

المناسبات	الموضوعات	العدد
	<ul style="list-style-type: none"> * التعبئة والتغليف * أنظمة التحميل / التفريغ والتخزين * حلول النقل * تكنولوجيا التغذية * سيور الرافعات الدلوية * مناولة المواد في مصانع الإسمنت والمحاجر والمحطات والموانئ * القباب والصوامع والنقل * الحماية من التآكل * التروس والمحركات والتزييت * أنظمة الحماية من الحريق * إجراءات الصيانة * الحراريات * تأهيل المحاجر * تنظيف الصوامع * المرشحات وإزالة الغبار 	<p>يونيو/حزيران 2023</p> <p>(العدد رقم 92)</p>
<p>المؤتمر والمعرض العربي الدولي السادس والعشرون لصناعة الإسمنت: الرياض / المملكة العربية السعودية نوفمبر / تشرين الثاني 2023</p>	<ul style="list-style-type: none"> * المبردات * المراوح * مدافع الهواء * الصحة والسلامة المهنية * تكنولوجيا الطحن * الطواحين العمودية * زيادة إنتاج مطحنة الإسمنت * التكسير * مساعدات الطحن والطحن * استعادة الحرارة المفقودة * التصوير الحراري * إعادة التدوير الحراري * طرق معالجة واستخدام غبار الممر الجانبي * الحماية من الانفجار في صوامع تخزين الوقود البديل * أنظمة مناولة الوقود البديل * إنتاج واستخدام الوقود الصلب المستعاد 	<p>سبتمبر/أيلول 2023</p> <p>(العدد رقم 93)</p>
	<ul style="list-style-type: none"> * تصنيع الإسمنت الأبيض * الإسمنت المخلوط * الإسمنت متعدد المكونات * إسمنت الخبث * إنتاج الإسمنت الأخضر * خلانات الإسمنت * مضافات الإسمنت * مكونات الإسمنت * كيمياء الإسمنت * الإسمنت الخالي من الكربون 	<p>ديسمبر/ كانون الأول 2023</p> <p>(العدد رقم 94)</p>

	* إنتاج الكلنكر منخفض الكربون * المواد الخام لمضافات الإسمنت * إدارة الإمدادات * إنتاج الإسمنت بطاقة منخفضة * توكيد الجودة ومراقبة العمليات في مصانع الإسمنت * توفير تكلفة إنتاج الإسمنت	
--	---	--

- آخر موعد لاستلام المقالات أو النصوص الصحفية أو الإعلانات لأعداد عام 2023 القادمة هو على النحو التالي :
1. عدد يونيو / حزيران : 30 مايو / أيار 2023
 2. عدد سبتمبر / أيلول (عدد خاص) : 31 أغسطس / آب 2023
 3. عدد ديسمبر / كانون أول : 5 ديسمبر / كانون الأول 2023

الإعلانات

(بالدولار الأمريكي)

الإعلان في عدد واحد	الإعلان في عددين	الإعلان في ثلاثة أعداد	الإعلان في أربعة أعداد	
1,250	*	*	*	غلاف خارجي ملون (يمين أو يسار) A4
950	*	*	*	غلاف داخلي ملون (يمين أو يسار) A4
750	950	1,250	1,350	صفحة داخلية ملونة A4
450	550	650	750	نصف صفحة داخلية ملونة A4
300	350	400	450	ربع صفحة داخلية ملونة A4
300	350	400	450	صفحة أسود وأبيض

أبعاد الإعلان : A4
أبعاد الإعلان على الغلاف الخارجي : ارتفاع 20 سم وعرض 14سم
الدقة : 300dpi
نوع الملف : PSD أو EPS أو PDF

WWW.AUCBM.NET إعلان على موقع الاتحاد

- عرض 200 بيكسل وارتفاع 75 بيكسل ، بقيمة 150 دولاراً أمريكياً في الشهر الواحد
- يرجى إرسال الصور مع اللينك المطلوب ربطه بها بدقة 300 dpi (dot per inch)

Advertisers: march edition # 91, 2023

	Page	
ALIT, group of companies Cement. Concrete. Dry mixtures	62	Website
Allan Smith Engineering PVT. LTD.	10	Website
CCPIT Building Materials Sub Council CEMENTTECH 2023	59	Website
CemWeek	6	Website
Global Cement Virtual (free) and in-person events	54	Website
International Cement Review	4	Website
Industrial Angles	51	Website
JAMCEM Consulting	26	Website
Journal Cement Magazine	14	Website1 Website2
Siman News – Iran Cement News Agency	76	Website
UAE Cement Portal Website	80	Website
VDZ Training Program 2023	53	Website
World Cement Association World Cement Network	57+58	Website
World Cement Magazine	71	Website
ZKG Cement Lime Gypsum	8	Website